

Enerdoor DC filter series is designed specifically for the photovoltaic industry. This series carries CE and UL approvals and offers a current range from 5 to 3000A with nominal voltage up to 1000 Vdc.

The FIN1220, FIN1520 and FIN7212 filters are installed between PV inverters and solar panels to reduce Electromagnetic interference in the DC power line.

The FIN1220.0V, FIN1520.0V and FIN7212 filters offer the possibility of ground connection separated from the virtual zero point. This is particularly beneficial for critical networks on the protective earth conductor.

This series features a compact case with screw and bus bar connectors. Customized solutions are available to satisfy various application requirements.

**DC Filter applications include:**

- Single phase machines up to 700 Vac
- Renewable energy
- Recharging stations
- AC/DC converters

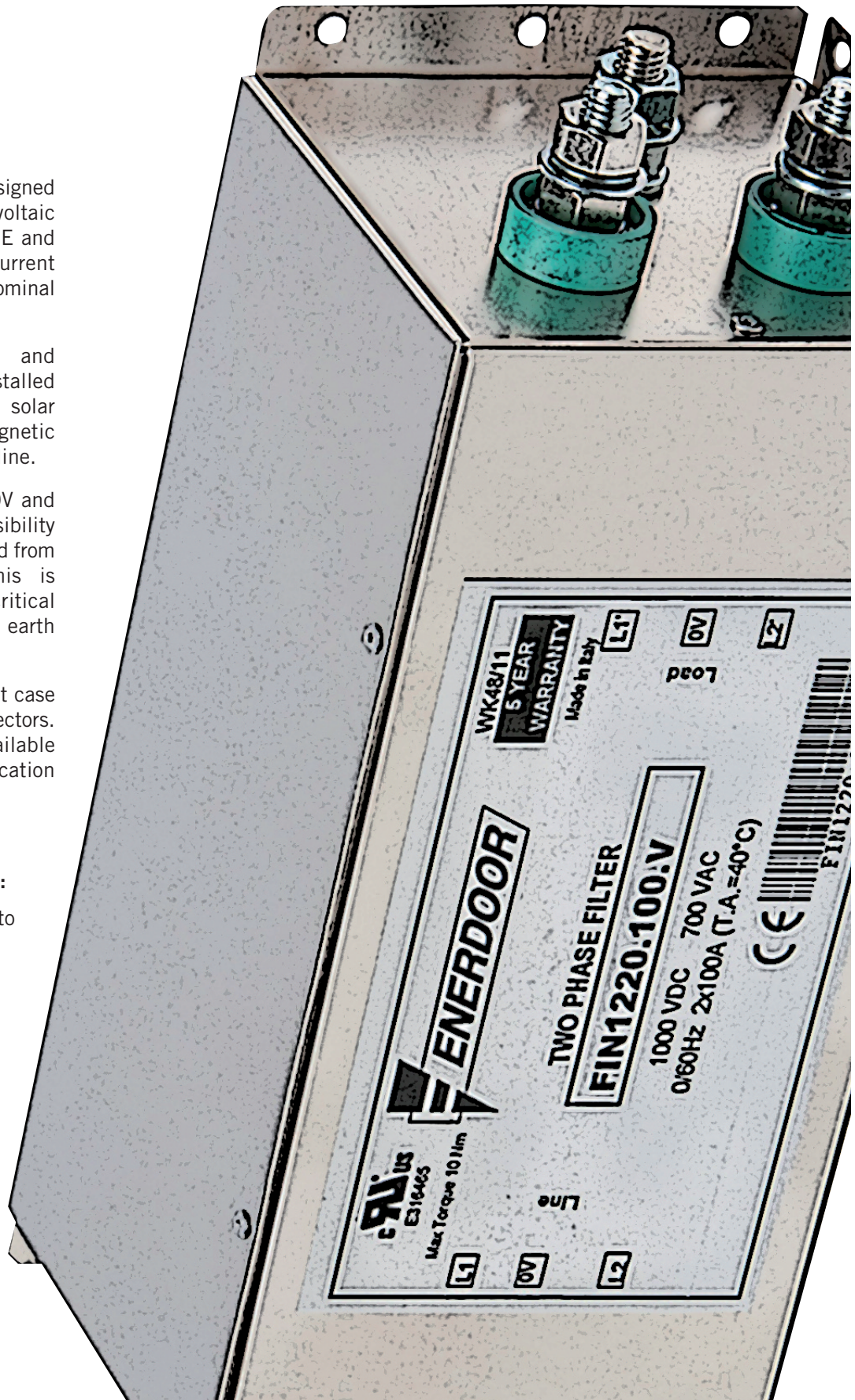



## EMI/RFI DC Filter with very high attenuation for DC industrial and residential applications

Datasheet 3/2017

### APPROVALS:



UL1283  
CSA C22.2



SCCR by UL508A

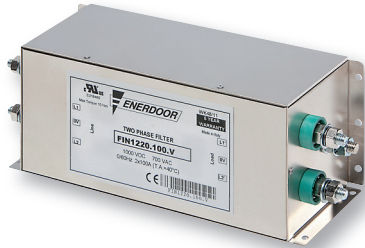

FIN1220.(005 - 280).V

### FEATURES

- Rated current from 5 to 3000A
- Very high common mode attenuation
- Very low leakage current

### BENEFITS

- 5 Year warranty
- Various connections available
- Finger safe protection upon request



FIN1220.(280 - 1750).B

### MARKETS

- Renewable energy
- Recharging stations
- AC/DC converters
- Single phase machines up to 700 Vac

### ORDERING CODE

FIN1220	.100	.V
Model	Current (A)	Connection
		V = Screw
		B = Bus bar

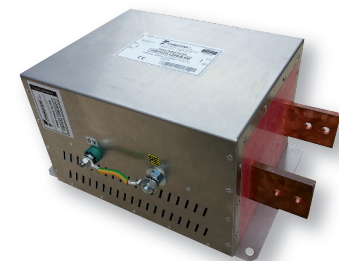

FIN1220.(2000 - 3000).B

### ATTENUATION INDICATOR

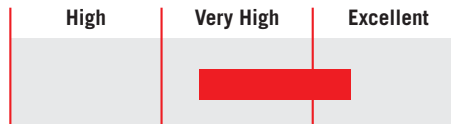

### ELECTRIC DIAGRAM

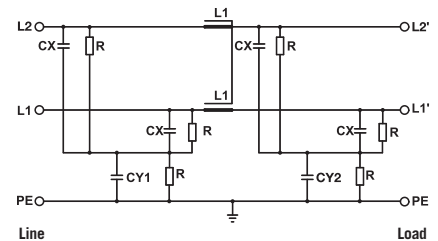

### TECHNICAL SPECIFICATIONS

Nominal voltage	0 / 1000 Vdc - 0 / 700 Vac
Frequency	50 – 60 Hz
Rated current	5 to 3000A
Potential test voltage phase to phase	3100 Vdc (2 sec.)
Potential test voltage phase to ground	3400 Vdc (2 sec.)
Leakage current normal conditions	< 3 mA *
Leakage current worst conditions	< 10 mA
IP Protection	IP20 up to 280 A, IP00 over**
Overload capability	4 x Rated current (Switch ON) 2 x In 10 seconds 1.5 In for 10 minutes
Climatic class	-40 / +85° C
MTBF at 40°C	250.000 Hrs

\* Voltage 230 Vac phase to ground 50Hz / 40°C  
\*\* IP20 available with protection FINPRT

### ELECTRICAL CHARACTERISTICS

FIN1220	Rated Current 40°C	Rated Current 50°C	Power Loss (W)
.005.V	7	5	5
.010.V	12	10	7
.016.V	18	16	14
.030.V	34	30	11
.050.V	55	50	10
.080.V	85	80	39
.100.V	110	100	45
.130.V	134	130	49
.150.V	160	150	69
.180.V	185	180	77
.200.V	210	200	85
.250.V	272	250	87
.280.V	297	280	77
.280.B	330	320	76
.320.B	330	320	77
.360.B	390	360	98
.400.B	435	400	102
.500.B	545	500	96
.600.B	654	600	102
.750.B	800	750	88
.900.B	940	900	72
.1000.B	1050	1000	102
.1250.B	1290	1250	96
.1500.B	1550	1500	108
.1600.B	1650	1600	115
.1750.B	1800	1750	120
.2000.B	2040	2000	122
.2250.B	2290	2250	127
.2500.B	2535	2500	140
.3000.B	3050	3000	150

### CONNECTIONS

LINE		PE	
d (mm)	Torque (Nm)	d1 (mm)	Torque (Nm)
M4	1.2	M4	1.2
M4	1.2	M4	1.2
M5	4	M5	4
M5	4	M5	4
M6	6	M5	4
M8	14	M8	14
M8	14	M8	14
M10	18	M10	18
M10	18	M10	18
M10	18	M10	18
M10	18	M10	18
M12	20	M10	18
M12	20	M10	18
M8	14	M10	18
M8	14	M10	18
M8	14	M10	18
M8	14	M10	18
M10	25	M10	18
M10	25	M10	18
M12	50	M12	20
M12	50	M12	20
M12	50	M12	20
M12	50	M12	20
M12	50	M12	20
M12	50	M12	20
M12	50	M12	20
M12	50	M12	20
M12	50	M12	20
M12	50	M12	20

### TYPICAL ATTENUATION

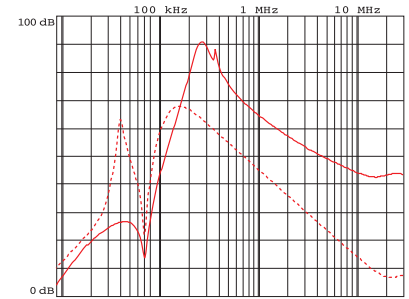

— Common Mode    - - - Differential Mode

Typical attenuation 7A – 400A

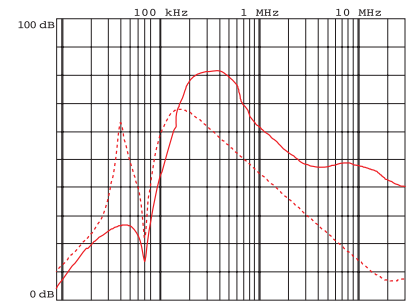

— Common Mode    - - - Differential Mode

Typical attenuation 500A – 3000A

**MECHANICAL DIMENSIONS mm**

FIN1220	A	B	C	d	d1	V	F	H	I	L	N	P	S	Weight Kg.	Case
.005.V	58	86	44	M4	M4	14	4.5	186	160	176	30	40	38	2	1
.010.V	58	86	44	M4	M4	14	4.5	186	160	176	30	40	38	2	1
.016.V	90	100	46	M5	M5	28	4.5	246	220	235	35	70	64	3	2
.030.V	90	100	46	M5	M5	28	4.5	246	220	235	35	70	64	3	2
.050.V	90	100	46	M6	M6	28	4.5	246	220	235	35	70	64	3	3
.080.V	90	100	40	M8	M8	28	4.5	246	220	235	35	70	69	3	4
.100.V	90	100	40	M8	M8	28	4.5	246	220	235	35	70	69	3	4
.130.V	90	185	120	M10	M10	29	6.5	356	320	340	77.5	70	60	5	5
.150.V	90	185	120	M10	M10	29	6.5	356	320	340	77.5	70	60	5	5
.180.V	90	185	120	M10	M10	29	6.5	356	320	340	77.5	70	60	5	5
.200.V	90	185	120	M10	M10	29	6.5	356	320	340	77.5	70	60	5	5
.250.V	90	200	120	M12	M12	30	6.5	356	320	340	95	70	60	7.5	6
.280.V	90	200	120	M12	M12	30	6.5	356	320	340	95	70	60	7.5	6

**CASE 1, 2, 3, 4**

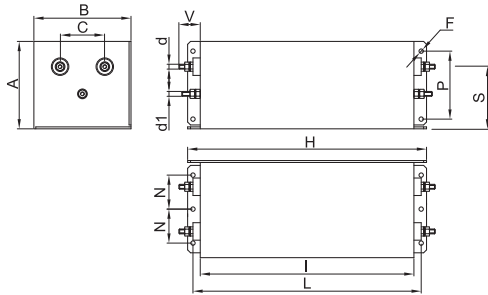

**ASSEMBLY CONNECTION "V"**

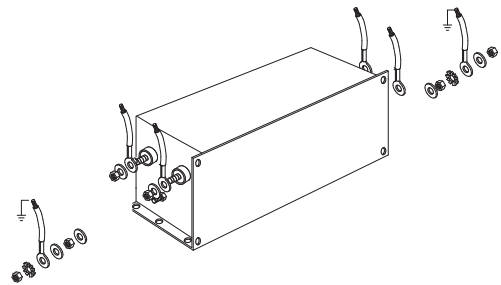

**CASE 5, 6**

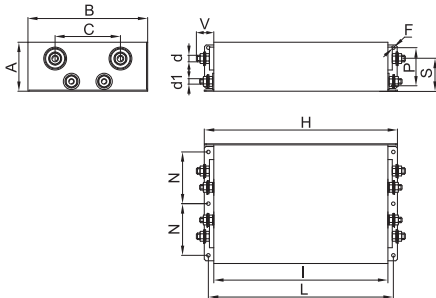

**ASSEMBLY CONNECTION "V"**

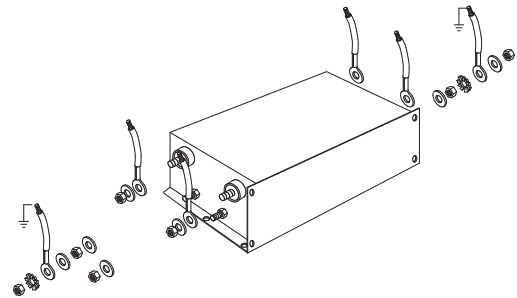

**MECHANICAL DIMENSIONS mm**

FIN1220	A	B	C	d	d1	d2	d3	V	F	H	I	L	N	N1	P	S	Weight Kg.	Case
.280.B	90	220	120	M8	M10	6	20	42	6.5	356	320	340	50	190	70	55	7.5	7
.320.B	90	220	120	M8	M10	6	20	42	6.5	356	320	340	50	190	70	55	7.5	7
.360.B	130	230	150	M8	M10	10	25	42	6.5	420	380	400	70	200	85	85	10	8
.400.B	130	230	150	M8	M10	10	25	42	6.5	420	380	400	70	200	85	85	10	8
.500.B	130	230	150	M8	M10	10	25	42	6.5	420	380	400	70	200	85	85	10	8
.600.B	130	230	150	M10	M10	15	30	48	6.5	510	450	480	70	200	100	85	15.5	9
.750.B	130	230	150	M10	M10	15	30	48	6.5	510	450	480	70	200	100	85	15.5	9
.900.B	160	250	140	M12	M12	20	40	94	8.5	510	450	480	70	200	110	110	23	10
.1000.B	160	250	140	M12	M12	20	40	94	8.5	510	450	480	70	200	110	110	23	10
.1250.B	160	250	140	M12	M12	20	40	94	8.5	510	450	480	70	200	110	110	23	10
.1500.B	180	300	200	M12	M12	20	60	97	8.5	560	500	530	80	250	130	117	27	11
.1600.B	180	300	200	M12	M12	20	60	97	8.5	560	500	530	80	250	130	117	27	11
.1750.B	180	300	200	M12	M12	20	60	97	8.5	560	500	530	80	250	130	117	27	11
.2000.B	225	350	200	M12	M12	25	80	100	8.5	610	550	580	150	-	-	112.5	45	12
.2250.B	225	350	200	M12	M12	25	80	100	8.5	610	550	580	150	-	-	112.5	45	12
.2500.B	225	350	200	M12	M12	25	80	100	8.5	610	550	580	150	-	-	112.5	45	12
.3000.B	225	350	200	M12	M12	25	80	100	8.5	610	550	580	150	-	-	112.5	45	12

**CASE 7, 8, 9**

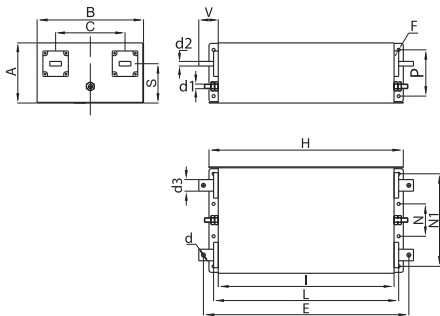

**ASSEMBLY CONNECTION "B"**

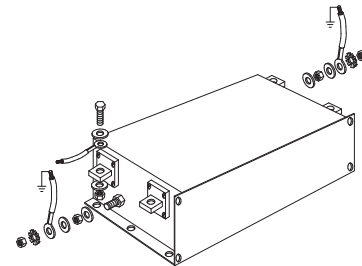

**CASE 10, 11**

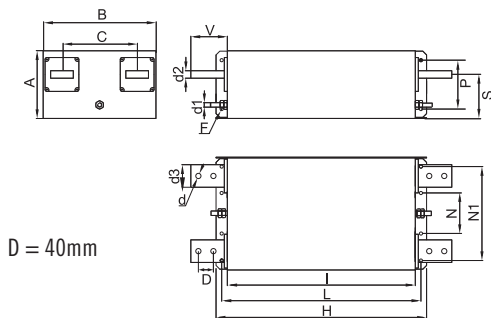

**ASSEMBLY CONNECTION "B"**

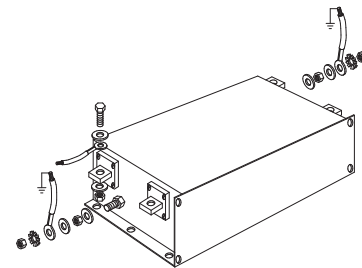

**CASE 12**

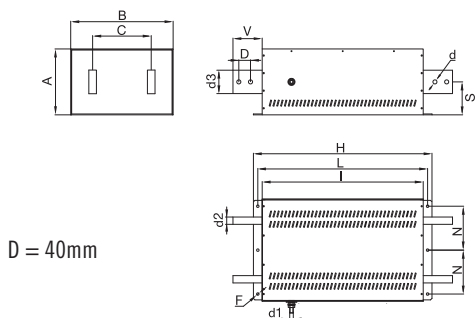

**ASSEMBLY CONNECTION "B"**

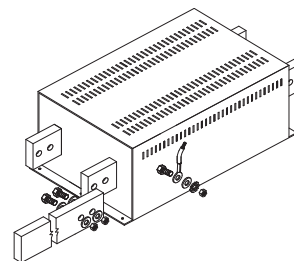



## EMI/RFI DC Filter with very high attenuation and zero volt insulated option for DC industrial applications

Datasheet 3/2017

### APPROVALS:



UL1283  
CSA C22.2



SCCR by UL508A

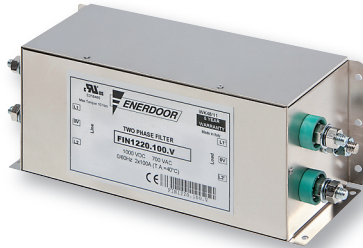

FIN1220.(005 - 280).0V

### FEATURES

- Rated current from 5 to 3000A
- Very high common mode attenuation
- Zero volt connector for PE floating system

### BENEFITS

- 5 Year warranty
- Various connections available
- Finger safe protection upon request



FIN1220.(280 - 1750).B.0V

### MARKETS

- Renewable energy
- Recharging stations
- AC/DC converters
- Single phase machines up to 700 Vac

### ORDERING CODE

FIN1220	.100	.V	.0V
Model	Current (A)	Connection	PE insulated
		V = Screw	
		B = Bus bar	

### ATTENUATION INDICATOR

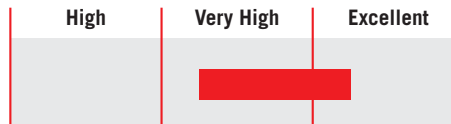

### ELECTRIC DIAGRAM

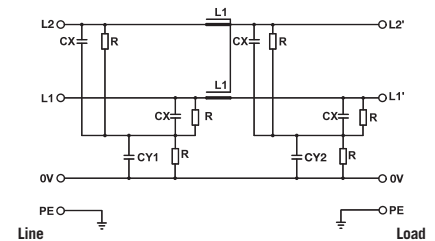

FIN1220.(2000 - 3000).B.0V

### TECHNICAL SPECIFICATIONS

Nominal voltage	0 / 1000 Vdc - 0 / 700 Vac
Frequency	50 – 60 Hz
Rated current	5 to 3000A
Potential test voltage phase to phase	3100 Vdc (2 sec.)
Potential test voltage phase to ground	3400 Vdc (2 sec.)
Leakage current normal conditions	< 3 mA *
Leakage current worst conditions	< 10 mA
IP Protection	IP20 up to 280 A, IP00 over**
Overload capability	4 x Rated current (Switch ON) 2 x In 10 seconds 1.5 In for 10 minutes
Climatic class	-40 / +85° C
MTBF at 40°C	250.000 Hrs

\* Voltage 230 Vac phase to ground 50Hz / 40°C  
\*\* IP20 available with protection FINPRT

### ELECTRICAL CHARACTERISTICS

FIN1220	Rated Current 40°C	Rated Current 50°C	Power Loss (W)
.005.V.OV	7	5	5
.010.V.OV	12	10	7
.016.V.OV	18	16	14
.030.V.OV	34	30	11
.050.V.OV	55	50	10
.080.V.OV	85	80	39
.100.V.OV	110	100	45
.130.V.OV	134	130	49
.150.V.OV	160	150	69
.180.V.OV	185	180	77
.200.V.OV	210	200	85
.250.V.OV	272	250	87
.280.V.OV	297	280	77
.280.B.OV	330	320	76
.320.B.OV	330	320	77
.360.B.OV	390	360	98
.400.B.OV	435	400	102
.500.B.OV	545	500	96
.600.B.OV	654	600	102
.750.B.OV	800	750	88
.900.B.OV	940	900	72
.1000.B.OV	1050	1000	102
.1250.B.OV	1290	1250	96
.1500.B.OV	1550	1500	108
.1600.B.OV	1650	1600	115
.1750.B.OV	1800	1750	120
.2000.B.OV	2040	2000	122
.2250.B.OV	2290	2250	127
.2500.B.OV	2535	2500	140
.3000.B.OV	3050	3000	150

### CONNECTIONS

LINE		PE		OV	
d (mm)	Torque (Nm)	d1 (mm)	Torque (Nm)	d4 (mm)	Torque (Nm)
M4	1.2	M4	1.2	M4	1.2
M4	1.2	M4	1.2	M4	1.2
M5	4	M5	4	M5	4
M5	4	M5	4	M5	4
M6	6	M5	4	M5	4
M8	14	M8	14	M6	6
M8	14	M8	14	M6	6
M10	18	M10	18	M10	18
M10	18	M10	18	M10	18
M10	18	M10	18	M10	18
M10	18	M10	18	M10	18
M12	20	M10	18	M10	18
M12	20	M10	18	M10	18
M8	14	M10	18	M10	18
M8	14	M10	18	M10	18
M8	14	M10	18	M10	18
M8	14	M10	18	M10	18
M10	25	M10	18	M10	18
M10	25	M10	18	M10	18
M12	50	M12	20	M12	20
M12	50	M12	20	M12	20
M12	50	M12	20	M12	20
M12	50	M12	20	M12	20
M12	50	M12	20	M12	20
M12	50	M12	20	M12	20
M12	50	M12	20	M12	20
M12	50	M12	20	M12	20
M12	50	M12	20	M12	20
M12	50	M12	20	M12	20

### TYPICAL ATTENUATION

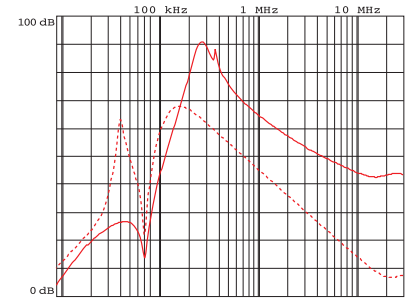

— Common Mode    - - - Differential Mode

Typical attenuation 5A – 400A

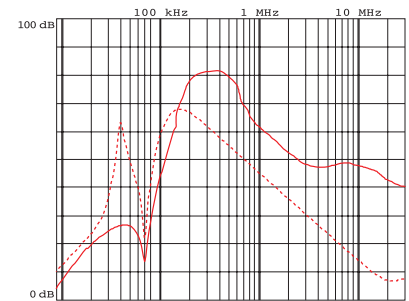

— Common Mode    - - - Differential Mode

Typical attenuation 500A – 3000A

**MECHANICAL DIMENSIONS mm**

FIN1220	A	B	C	d	d1	d4	V	F	H	I	L	N	P	S	Weight Kg.	Case
.005.V.0V	58	86	44	M4	M4	M4	14	4.5	186	160	176	30	40	38	2	1
.010.V.0V	58	86	44	M4	M4	M4	14	4.5	186	160	176	30	40	38	2	1
.016.V.0V	90	100	46	M5	M5	M5	28	4.5	246	220	235	35	70	64	3	2
.030.V.0V	90	100	46	M5	M5	M5	28	4.5	246	220	235	35	70	64	3	2
.050.V.0V	90	100	46	M6	M5	M5	28	4.5	246	220	235	35	70	64	3	3
.080.V.0V	90	100	40	M8	M8	M6	28	4.5	246	220	235	35	70	69	3	4
.100.V.0V	90	100	40	M8	M8	M6	28	4.5	246	220	235	35	70	69	3	4
.130.V.0V	90	185	120	M10	M10	M10	29	6.5	356	320	340	77.5	70	60	5	5
.150.V.0V	90	185	120	M10	M10	M10	29	6.5	356	320	340	77.5	70	60	5	5
.180.V.0V	90	185	120	M10	M10	M10	29	6.5	356	320	340	77.5	70	60	5	5
.200.V.0V	90	185	120	M10	M10	M10	29	6.5	356	320	340	77.5	70	60	5	5
.250.V.0V	90	200	120	M12	M10	M10	30	6.5	356	320	340	95	70	60	7.5	6
.280.V.0V	90	200	120	M12	M10	M10	30	6.5	356	320	340	95	70	60	7.5	6

**CASE 1, 2, 3, 4**

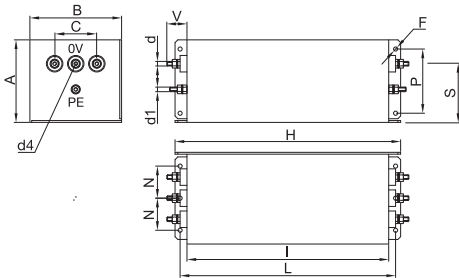

**ASSEMBLY CONNECTION "V"**

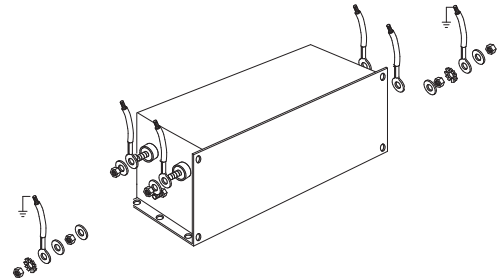

**CASE 5, 6**

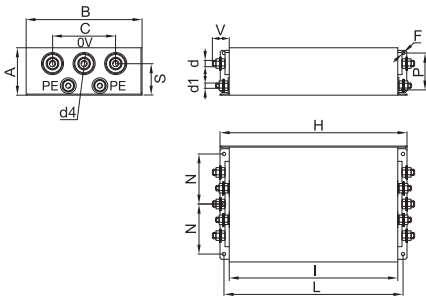

**ASSEMBLY CONNECTION "V"**

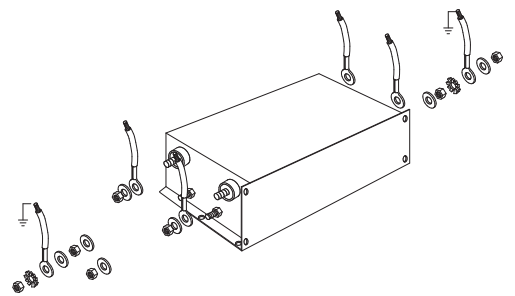



**MECHANICAL DIMENSIONS mm**

FIN1220	A	B	C	d	d1	d2	d3	d4	V	F	H	I	L	N	N1	P	S	Weight Kg.	Case
.280.B.0V	90	220	120	M8	M10	6	20	M10	42	6.5	356	320	340	50	190	70	55	7.5	7
.320.B.0V	90	220	120	M8	M10	6	20	M10	42	6.5	356	320	340	50	190	70	55	7.5	7
.360.B.0V	130	230	150	M8	M10	10	25	M10	42	6.5	420	380	400	70	200	85	85	10	8
.400.B.0V	130	230	150	M8	M10	10	25	M10	42	6.5	420	380	400	70	200	85	85	10	8
.500.B.0V	130	230	150	M8	M10	10	25	M10	42	6.5	420	380	400	70	200	85	85	10	8
.600.B.0V	130	230	150	M10	M10	15	30	M10	48	6.5	510	450	480	70	200	100	85	15.5	9
.750.B.0V	130	230	150	M10	M10	15	30	M10	48	6.5	510	450	480	70	200	100	85	15.5	9
.900.B.0V	160	250	140	M12	M12	20	40	M12	94	8.5	510	450	480	70	200	110	110	23	10
.1000.B.0V	160	250	140	M12	M12	20	40	M12	94	8.5	510	45	480	70	200	110	110	23	10
.1250.B.0V	160	250	140	M12	M12	20	40	M12	94	8.5	510	450	480	70	200	110	110	23	10
.1500.B.0V	180	300	200	M12	M12	20	60	M12	97	8.5	560	500	530	80	250	130	117	27	11
.1600.B.0V	180	300	200	M12	M12	20	60	M12	97	8.5	560	500	530	80	250	130	117	27	11
.1750.B.0V	180	300	200	M12	M12	20	60	M12	97	8.5	560	500	530	80	250	130	117	27	11
.2000.B.0V	225	350	200	M12	M12	25	80	M12	100	8.5	610	550	580	150	-	-	112.5	45	12
.2250.B.0V	225	350	200	M12	M12	25	80	M12	100	8.5	610	550	580	150	-	-	112.5	45	12
.2500.B.0V	225	350	200	M12	M12	25	80	M12	100	8.5	610	550	580	150	-	-	112.5	45	12
.3000.B.0V	225	350	200	M12	M12	25	80	M12	100	8.5	610	550	580	150	-	-	112.5	45	12

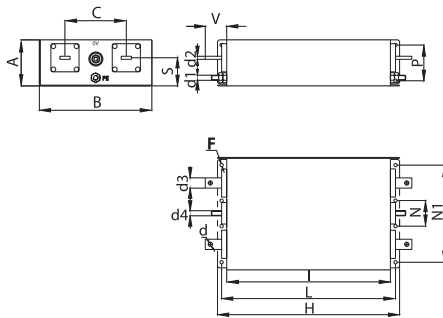
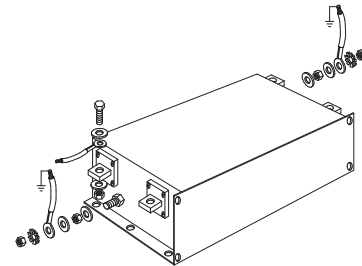
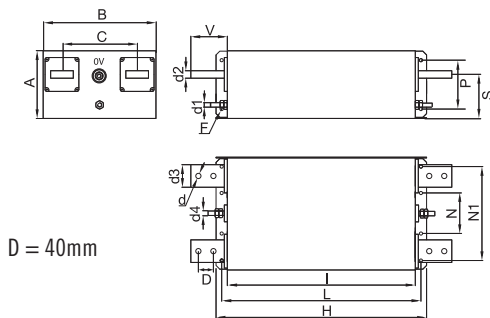
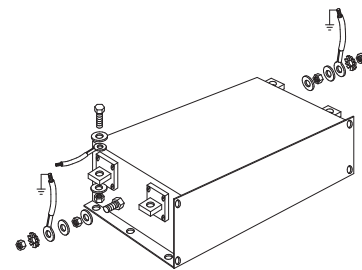
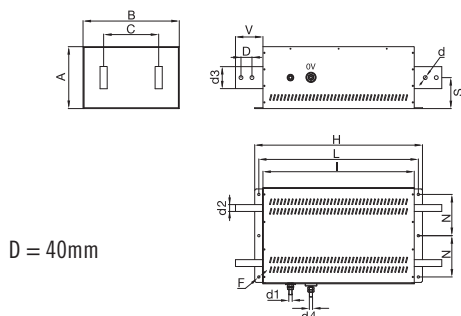
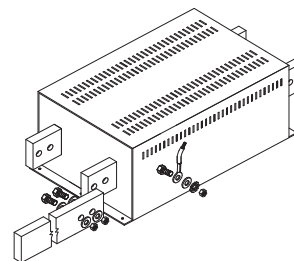
**CASE 7, 8, 9**

**ASSEMBLY CONNECTION "B"**

**CASE 10, 11**

**ASSEMBLY CONNECTION "B"**

**CASE 12**

**ASSEMBLY CONNECTION "B"**



## EMI/RFI DC Filter with excellent attenuation performance for DC industrial applications

Datasheet 3/2017

### APPROVALS:



UL1283  
CSA C22.2

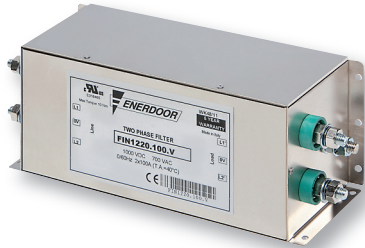

**FIN1520.(005 - 280).V**



**FIN1520.(280 - 1750).B**



**FIN1520.(2000 - 3000).B**

### FEATURES

- Rated current from 5 to 3000A
- Excellent common mode attenuation
- Low leakage current

### BENEFITS

- 5 Year warranty
- Compact case
- EMI noise and spike reduction

### MARKETS

- Renewable energy
- Recharging stations
- AC/DC converters
- Single phase machines up to 700 Vac

### ORDERING CODE

FIN1520	.100	.V
Model	Current (A)	Connection
		V = Screw
		B = Bus bar

### ATTENUATION INDICATOR

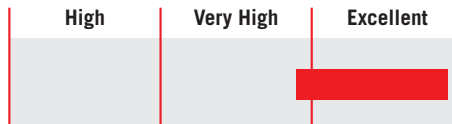

### ELECTRIC DIAGRAM

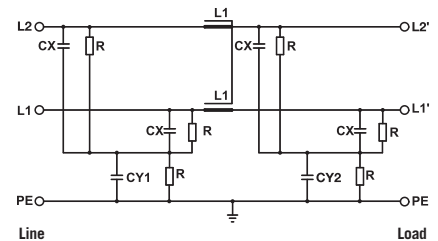

### TECHNICAL SPECIFICATIONS

Nominal voltage	0 / 1000 Vdc - 0 / 700 Vac
Frequency	50 – 60 Hz
Rated current	5 to 3000A
Potential test voltage phase to phase	3100 Vdc (2 sec.)
Potential test voltage phase to ground	3400 Vdc (2 sec.)
Leakage current normal conditions	<10 mA *
Leakage current worst conditions	<80 mA
IP Protection	IP20 up to 280 A, IP00 over**
Overload capability	4 x Rated current (Switch ON) 2 x In 10 seconds 1.5 In for 10 minutes
Climatic class	-40 / +85° C
MTBF at 40°C	250.000 Hrs

\* Voltage 230 Vac phase to ground 50Hz / 40°C  
\*\* IP20 available with protection FINPRT

### ELECTRICAL CHARACTERISTICS

FIN1520	Rated Current 40°C	Rated Current 50°C	Power Loss (W)
.005.V	7	5	5
.010.V	12	10	7
.016.V	18	16	14
.030.V	34	30	11
.050.V	55	50	10
.080.V	85	80	39
.100.V	110	100	45
.130.V	134	130	49
.150.V	160	150	69
.180.V	185	180	77
.200.V	210	200	85
.250.V	272	250	87
.280.V	297	280	77
.280.B	330	320	76
.320.B	330	320	77
.360.B	390	360	98
.400.B	435	400	102
.500.B	545	500	96
.600.B	654	600	102
.750.B	800	750	88
.900.B	940	900	72
.1000.B	1050	1000	102
.1250.B	1290	1250	96
.1500.B	1550	1500	108
.1600.B	1650	1600	115
.1750.B	1800	1750	120
.2000.B	2040	2000	122
.2250.B	2290	2250	127
.2500.B	2535	2500	140
.3000.B	3050	3000	150

### CONNECTIONS

LINE		PE	
d (mm)	Torque (Nm)	d1 (mm)	Torque (Nm)
M4	1.2	M4	1.2
M4	1.2	M4	1.2
M5	4	M5	4
M5	4	M5	4
M6	6	M5	4
M8	14	M8	14
M8	14	M8	14
M10	18	M10	18
M10	18	M10	18
M10	18	M10	18
M10	18	M10	18
M12	20	M10	18
M12	20	M10	18
M8	14	M10	18
M8	14	M10	18
M8	14	M10	18
M8	14	M10	18
M10	25	M10	18
M10	25	M10	18
M12	50	M12	20
M12	50	M12	20
M12	50	M12	20
M12	50	M12	20
M12	50	M12	20
M12	50	M12	20
M12	50	M12	20
M12	50	M12	20
M12	50	M12	20
M12	50	M12	20

### TYPICAL ATTENUATION

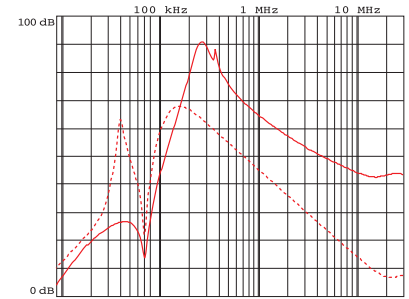

— Common Mode    - - - Differential Mode

Typical attenuation 5A - 400A

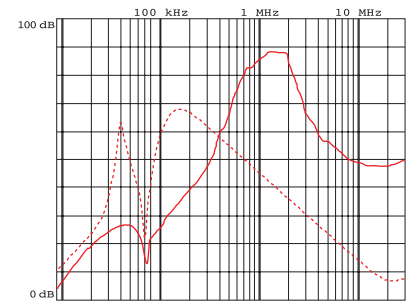

— Common Mode    - - - Differential Mode

Typical attenuation 500A - 3000A

**MECHANICAL DIMENSIONS mm**

FIN1520	A	B	C	d	d1	V	F	H	I	L	N	P	S	Weight Kg.	Case
.005.V	58	86	44	M4	M4	14	4.5	186	160	176	30	40	38	2	1
.010.V	58	86	44	M4	M4	14	4.5	186	160	176	30	40	38	2	1
.016.V	90	100	46	M5	M5	28	4.5	246	220	235	35	70	64	3	2
.030.V	90	100	46	M5	M5	28	4.5	246	220	235	35	70	64	3	2
.050.V	90	100	46	M6	M5	28	4.5	246	220	235	35	70	64	3	3
.080.V	90	100	40	M8	M8	28	4.5	246	220	235	35	70	69	3	4
.100.V	90	100	40	M8	M8	28	4.5	246	220	235	35	70	69	3	4
.130.V	90	185	120	M10	M10	29	6.5	356	320	340	77.5	70	60	5	5
.150.V	90	185	120	M10	M10	29	6.5	356	320	340	77.5	70	60	5	5
.180.V	90	185	120	M10	M10	29	6.5	356	320	340	77.5	70	60	5	5
.200.V	90	185	120	M10	M10	29	6.5	356	320	340	77.5	70	60	5	5
.250.V	90	200	120	M12	M10	30	6.5	356	320	340	95	70	60	7.5	6
.280.V	90	200	120	M12	M10	30	6.5	356	320	340	95	70	60	7.5	6

**CASE 1, 2, 3, 4**

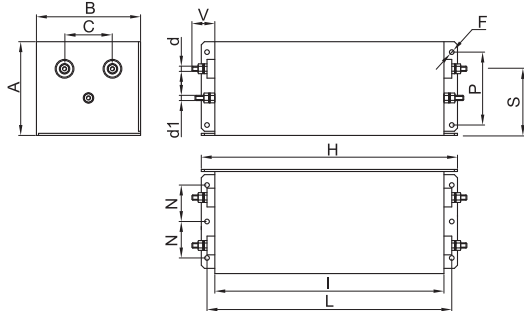

**ASSEMBLY CONNECTION "V"**

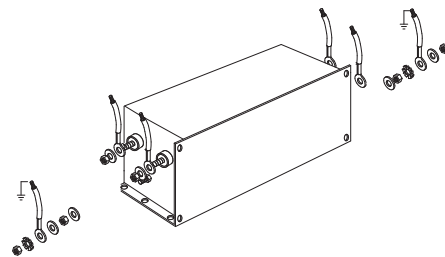

**CASE 5, 6**

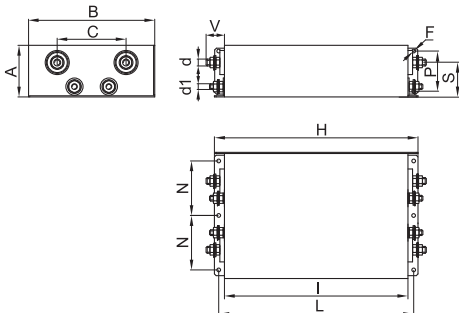

**ASSEMBLY CONNECTION "V"**

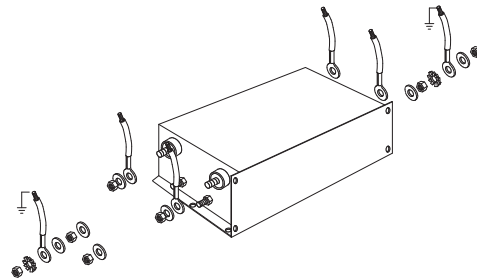

**MECHANICAL DIMENSIONS mm**

FIN1520	A	B	C	d	d1	d2	d3	V	F	H	I	L	N	N1	P	S	Weight Kg.	Case
.280.B	90	220	120	M8	M10	6	20	42	6.5	356	320	340	50	190	70	55	7.5	7
.320.B	90	220	120	M8	M10	6	20	42	6.5	356	320	340	50	190	70	55	7.5	7
.360.B	130	230	150	M8	M10	10	25	42	6.5	420	380	400	70	200	85	85	10	8
.400.B	130	230	150	M8	M10	10	25	42	6.5	420	380	400	70	200	85	85	10	8
.500.B	130	230	150	M8	M10	10	25	42	6.5	420	380	400	70	200	85	85	10	8
.600.B	130	230	150	M10	M10	15	30	48	6.5	510	450	480	70	200	100	85	15.5	9
.750.B	130	230	150	M10	M10	15	30	48	6.5	510	450	480	70	200	100	85	15.5	9
.900.B	160	250	140	M12	M12	20	40	94	8.5	510	450	480	70	200	110	110	23	10
.1000.B	160	250	140	M12	M12	20	40	94	8.5	510	450	480	70	200	110	110	23	10
.1250.B	160	250	140	M12	M12	20	40	94	8.5	510	450	480	70	200	110	110	23	10
.1500.B	180	300	200	M12	M12	20	60	97	8.5	560	500	530	80	250	130	117	27	11
.1600.B	180	300	200	M12	M12	20	60	97	8.5	560	500	530	80	250	130	117	27	11
.1750.B	180	300	200	M12	M12	20	60	97	8.5	560	500	530	80	250	130	117	27	11
.2000.B	225	350	200	M12	M12	25	80	100	8.5	610	550	580	150	-	-	112.5	45	12
.2250.B	225	350	200	M12	M12	25	80	100	8.5	610	550	580	150	-	-	112.5	45	12
.2500.B	225	350	200	M12	M12	25	80	100	8.5	610	550	580	150	-	-	112.5	45	12
.3000.B	225	350	200	M12	M12	25	80	100	8.5	610	550	580	150	-	-	112.5	45	12

**CASE 7, 8, 9**

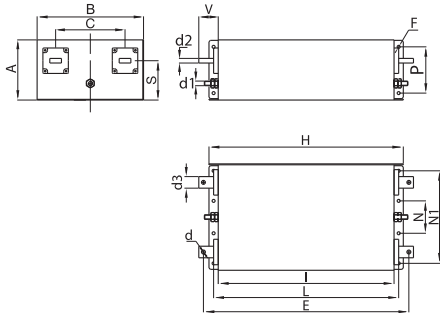

**ASSEMBLY CONNECTION "B"**

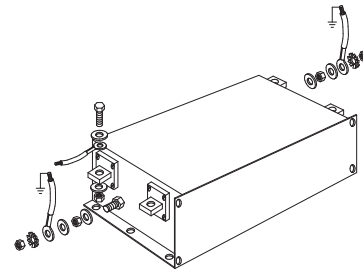

**CASE 10, 11**

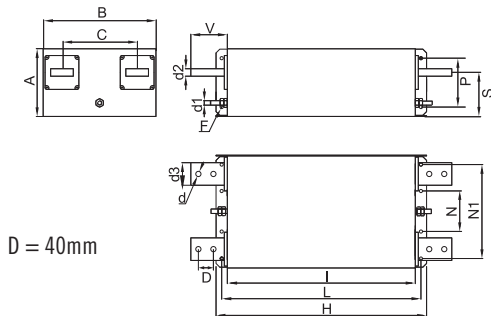

**ASSEMBLY CONNECTION "B"**

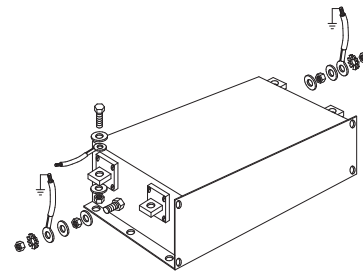

**CASE 12**

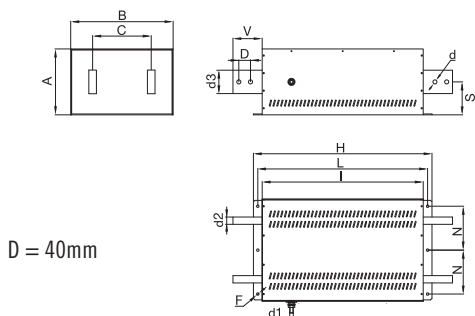

**ASSEMBLY CONNECTION "B"**

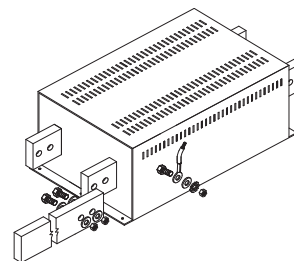



## EMI/RFI DC Filter with excellent attenuation for DC industrial applications

Datasheet 3/2017

### APPROVALS:



UL1283  
CSA C22.2



SCCR by UL508A

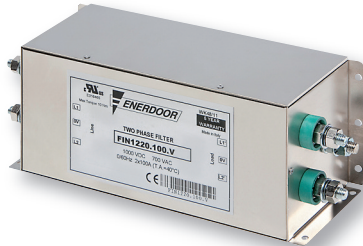

**FIN1520.(005 - 280).V.0V**

### FEATURES

- Rated current from 5 to 3000A
- Excellent common mode attenuation
- Low leakage current

### BENEFITS

- 5 Year warranty
- Various connections available
- Zero volt insulated available



**FIN1520.(280 - 1750).B.0V**

### MARKETS

- Renewable energy
- AC/DC converters
- Single phase machines up to 700 Vac

### ORDERING CODE

FIN1520	.100	.V	.0V
Model	Current (A)	Connection	PE insulated
		V = Screw	
		B = Bus bar	



**FIN1520.(2000 - 3000).B.0V**

Vertical bus bar connections available upon request

### ATTENUATION INDICATOR

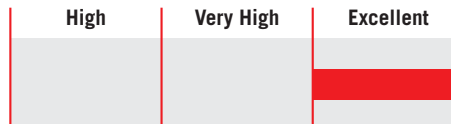

### ELECTRIC DIAGRAM

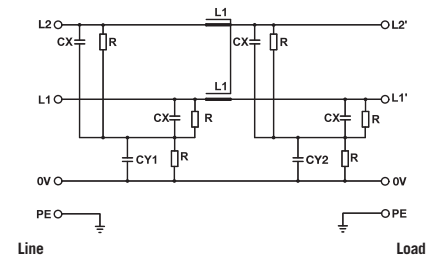

### TECHNICAL SPECIFICATIONS

Nominal voltage	0 / 1000 Vdc - 0 / 700 Vac
Frequency	50 - 60 Hz
Rated current	5 to 3000A
Potential test voltage phase to phase	3100 Vdc (2 sec.)
Potential test voltage phase to ground	3400 Vdc (2 sec.)
Leakage current normal conditions	< 10 mA *
Leakage current worst conditions	< 80 mA
IP Protection	IP20 up to 280 A, IP00 over**
Overload capability	4 x Rated current (Switch ON) 2 x In 10 seconds 1.5 In for 10 minutes
Climatic class	-40 / +85° C
MTBF at 40°C	250.000 Hrs

\* Voltage 230 Vac phase to ground 50Hz / 40°C  
\*\* IP20 available with protection FINPRT

### ELECTRICAL CHARACTERISTICS

FIN1520	Rated Current 40°C	Rated Current 50°C	Power Loss (W)
.005.V.0V	7	5	5
.010.V.0V	12	10	7
.016.V.0V	18	16	14
.030.V.0V	34	30	11
.050.V.0V	55	50	10
.080.V.0V	85	80	39
.100.V.0V	110	100	45
.130.V.0V	134	130	49
.150.V.0V	160	150	69
.180.V.0V	185	180	77
.200.V.0V	210	200	85
.250.V.0V	272	250	87
.280.V.0V	297	280	77
.280.B.0V	330	320	76
.320.B.0V	330	320	77
.360.B.0V	390	360	98
.400.B.0V	435	400	102
.500.B.0V	545	500	96
.600.B.0V	654	600	102
.750.B.0V	800	750	88
.900.B.0V	940	900	72
.1000.B.0V	1050	1000	102
.1250.B.0V	1290	1250	96
.1500.B.0V	1550	1500	108
.1600.B.0V	1650	1600	115
.1750.B.0V	1800	1750	120
.2000.B.0V	2040	2000	122
.2250.B.0V	2290	2250	127
.2500.B.0V	2535	2500	140
.3000.B.0V	3050	3000	150

### CONNECTIONS

LINE		PE		OV	
d (mm)	Torque (Nm)	d1 (mm)	Torque (Nm)	d4 (mm)	Torque (Nm)
M4	1.2	M4	1.2	M4	1.2
M4	1.2	M4	1.2	M4	1.2
M5	4	M5	4	M5	4
M5	4	M5	4	M5	4
M6	6	M5	4	M5	4
M8	14	M8	14	M6	6
M8	14	M8	14	M6	6
M10	18	M10	18	M10	18
M10	18	M10	18	M10	18
M10	18	M10	18	M10	18
M10	18	M10	18	M10	18
M12	20	M10	18	M10	18
M12	20	M10	18	M10	18
M8	14	M10	18	M10	18
M8	14	M10	18	M10	18
M8	14	M10	18	M10	18
M8	14	M10	18	M10	18
M10	25	M10	18	M10	18
M10	25	M10	18	M10	18
M12	50	M12	20	M12	20
M12	50	M12	20	M12	20
M12	50	M12	20	M12	20
M12	50	M12	20	M12	20
M12	50	M12	20	M12	20
M12	50	M12	20	M12	20
M12	50	M12	20	M12	20
M12	50	M12	20	M12	20
M12	50	M12	20	M12	20
M12	50	M12	20	M12	20

### TYPICAL ATTENUATION

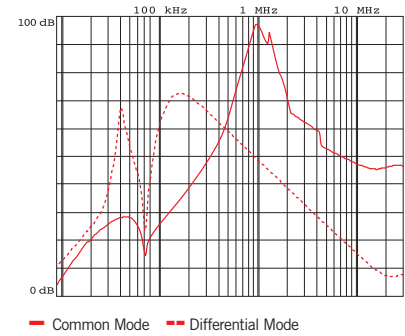

Typical attenuation 5A - 400A

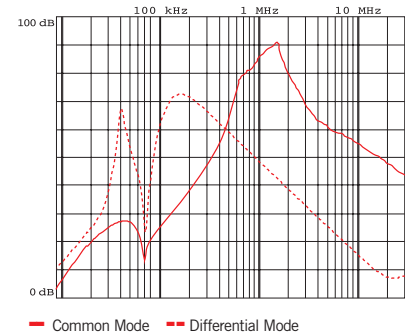

Typical attenuation 500A - 3000A

**MECHANICAL DIMENSIONS mm**

FIN1520	A	B	C	d	d1	d4	V	F	H	I	L	N	P	S	Weight Kg.	Case
.005.V.0V	58	86	44	M4	M4	M4	14	4.5	186	160	176	30	40	38	2	1
.010.V.0V	58	86	44	M4	M4	M4	14	4.5	186	160	176	30	40	38	2	1
.016.V.0V	90	100	46	M5	M5	M5	28	4.5	246	220	235	35	70	64	3	2
.030.V.0V	90	100	46	M5	M5	M5	28	4.5	246	220	235	35	70	64	3	2
.050.V.0V	90	100	46	M6	M5	M5	28	4.5	246	220	235	35	70	64	3	3
.080.V.0V	90	100	40	M8	M8	M6	28	4.5	246	220	235	35	70	69	3	4
.100.V.0V	90	100	40	M8	M8	M6	28	4.5	246	220	235	35	70	69	3	4
.130.V.0V	90	185	120	M10	M10	M10	29	6.5	356	320	340	77.5	70	60	5	5
.150.V.0V	90	185	120	M10	M10	M10	29	6.5	356	320	340	77.5	70	60	5	5
.180.V.0V	90	185	120	M10	M10	M10	29	6.5	356	320	340	77.5	70	60	5	5
.200.V.0V	90	185	120	M10	M10	M10	29	6.5	356	320	340	77.5	70	60	5	5
.250.V.0V	90	200	120	M12	M10	M10	30	6.5	356	320	340	95	70	60	7.5	6
.280.V.0V	90	200	120	M12	M10	M10	30	6.5	356	320	340	95	70	60	7.5	6

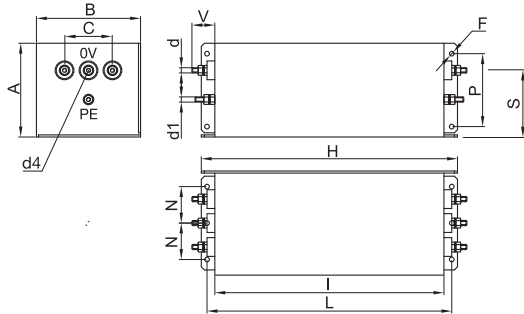
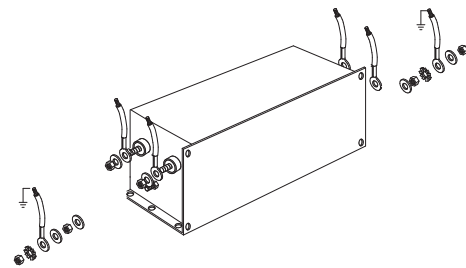
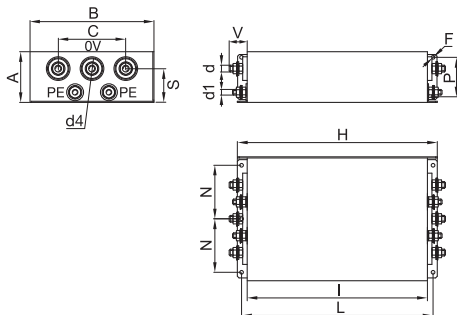
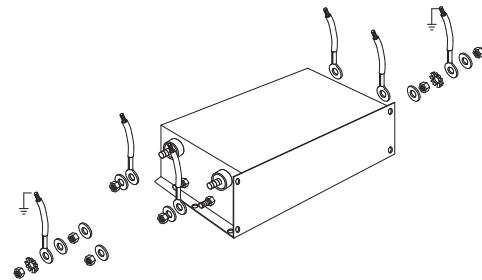
**CASE 1, 2, 3, 4**

**ASSEMBLY CONNECTION "V"**

**CASE 5, 6**

**ASSEMBLY CONNECTION "V"**

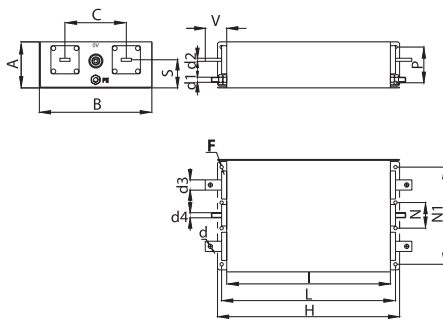
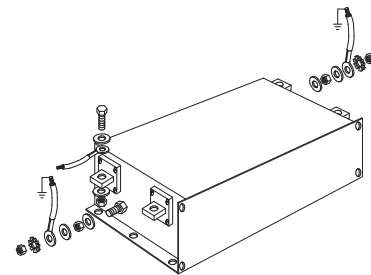
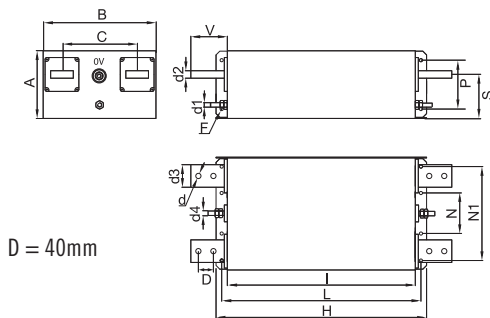
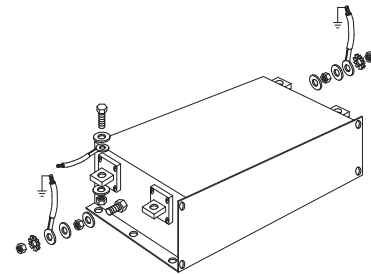
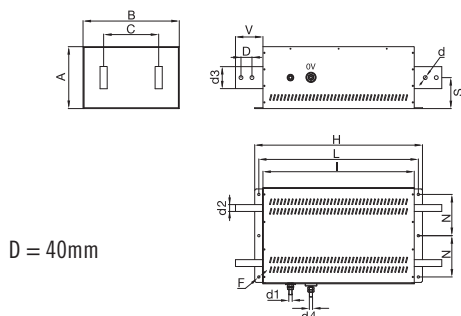
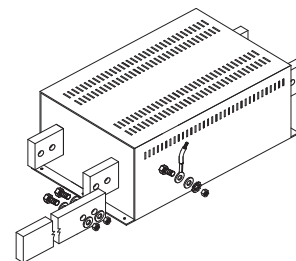

**MECHANICAL DIMENSIONS mm**

FIN1520	A	B	C	d	d1	d2	d3	d4	V	F	H	I	L	N	N1	P	S	Weight Kg.	Case
.280.B.0V	90	220	120	M8	M10	6	20	M10	42	6.5	356	320	340	50	190	70	55	7.5	7
.320.B.0V	90	220	120	M8	M10	6	20	M10	42	6.5	356	320	340	50	190	70	55	7.5	7
.360.B.0V	130	230	150	M8	M10	10	25	M10	42	6.5	420	380	400	70	200	85	85	10	8
.400.B.0V	130	230	150	M8	M10	10	25	M10	42	6.5	420	380	400	70	200	85	85	10	8
.500.B.0V	130	230	150	M8	M10	10	25	M10	42	6.5	420	380	400	70	200	85	85	10	8
.600.B.0V	130	230	150	M10	M10	15	30	M10	48	6.5	510	450	480	70	200	100	85	15.5	9
.750.B.0V	130	230	150	M10	M10	15	30	M10	48	6.5	510	450	480	70	200	100	85	15.5	9
.900.B.0V	160	250	140	M12	M12	20	40	M12	94	8.5	510	450	480	70	200	110	110	23	10
.1000.B.0V	160	250	140	M12	M12	20	40	M12	94	8.5	510	45	480	70	200	110	110	23	10
.1250.B.0V	160	250	140	M12	M12	20	40	M12	94	8.5	510	450	480	70	200	110	110	23	10
.1500.B.0V	180	300	200	M12	M12	20	60	M12	97	8.5	560	500	530	80	250	130	117	27	11
.1600.B.0V	180	300	200	M12	M12	20	60	M12	97	8.5	560	500	530	80	250	130	117	27	11
.1750.B.0V	180	300	200	M12	M12	20	60	M12	97	8.5	560	500	530	80	250	130	117	27	11
.2000.B.0V	225	350	200	M12	M12	25	80	M12	100	8.5	610	550	580	150	-	-	112.5	45	12
.2250.B.0V	225	350	200	M12	M12	25	80	M12	100	8.5	610	550	580	150	-	-	112.5	45	12
.2500.B.0V	225	350	200	M12	M12	25	80	M12	100	8.5	610	550	580	150	-	-	112.5	45	12
.3000.B.0V	225	350	200	M12	M12	25	80	M12	100	8.5	610	550	580	150	-	-	112.5	45	12

**CASE 7, 8, 9**

**ASSEMBLY CONNECTION "B"**

**CASE 10, 11**

**ASSEMBLY CONNECTION "B"**

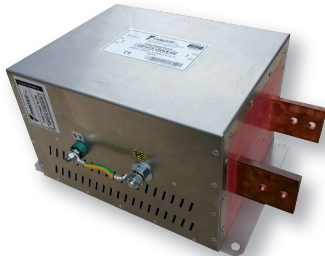
**CASE 12**

**ASSEMBLY CONNECTION "B"**



## EMI/RFI DC Filter with excellent attenuation for DC industrial applications

Datasheet 3/2017

**APPROVALS:**

**FIN7212.(150 - 1500).B**

Models available with current ratings up to 3000A upon request

**FEATURES**

- Rated current from 150 to 1500A
- Excellent differential and common mode attenuation
- Low leakage current

**BENEFITS**

- 5 Year warranty
- Very compact case
- Finger safe protection upon request
- Zero volt option

**MARKETS**

- Electrical equipment
- Machine tools
- Industrial automation
- Variable frequency drives / servo drives
- Regenerative systems
- Renewable energy

**ORDERING CODE**

FIN7212	.100	.B	.0V
Model	Current (A)	Connection	zero volt connection optional
		B = Bus bar	

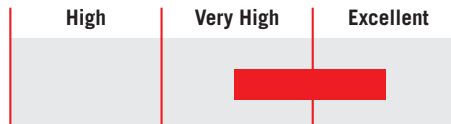
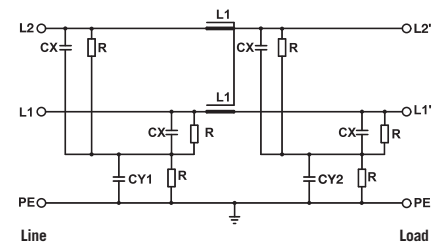
**ATTENUATION INDICATOR**

**ELECTRIC DIAGRAM**

**TECHNICAL SPECIFICATIONS**

	<b>FIN7212</b>
Nominal voltage	0 / 1000 Vdc - 0/700Vac
Frequency	50 – 60 Hz
Rated current	150 to 1500A
Potential test voltage phase to phase	2400 Vdc (2 sec.)
Potential test voltage phase to ground	3200 Vdc (2 sec.)
Leakage current normal conditions	< 10 mA
Leakage current worst conditions	< 35 mA *
IP Protection	IP00 over
Overload capability	4 x Rated current (Switch ON) 2 x In 10 seconds 1.5 In for 10 minutes
Climatic class	-40 / +85° C
MTBF at 40°C	250.000 Hrs

\* Voltage 230 Vac phase to ground 50Hz / 40°C

### ELECTRICAL CHARACTERISTICS

FIN7212	Rated Current 40°C	Rated Current 50°C	Power Loss (W)
.150.B	150	135	65
.200.B	200	180	70
.280.B	280	250	75
.320.B	320	290	80
.400.B	400	360	110
.500.B	500	450	102
.600.B	600	540	95
.750.B	750	675	80
.900.B	900	810	90
.1000.B	1000	900	100
.1500.B	1500	1350	110

### CONNECTIONS

LINE		PE	
d (mm)	Torque (Nm)	d1 (mm)	Torque (Nm)
M8	14	M8	10
M8	14	M8	10
M8	14	M8	10
M8	14	M8	10
M8	14	M8	10
M8	14	M8	10
M10	18	M8	10
M10	18	M8	10
M10	18	M8	10
M10	18	M8	10
M10	18	M10	18

### TYPICAL ATTENUATION

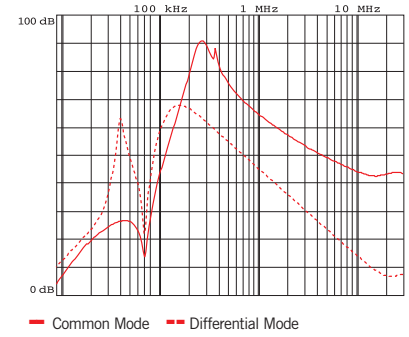

Typical attenuation 150A - 1500A

**MECHANICAL DIMENSIONS mm**

FIN7212	A	B	C	D	E	H	I	L	N	P	S	d	d2	Weight Kg.	Case
.150.B	86	200	120	300	227	300	240	275	165	320	37	9	20x6	4.5	1
.200.B	86	200	120	300	227	300	240	275	165	320	37	9	20x6	4.6	1
.280.B	86	200	120	300	227	300	240	275	165	320	37	9	20x6	4.7	1
.320.B	86	200	120	300	227	300	240	275	165	320	37	9	20x6	4.75	1
.400.B	86	200	120	300	227	300	240	275	165	320	37	9	20x6	4.8	1
.500.B	125	200	120	295	222	300	240	275	200	320	62.5	11	35x1	7.7	2
.600.B	125	200	120	295	222	300	240	275	200	320	62.5	11	35x10	7.8	2
.750.B	125	200	120	295	222	300	240	275	200	320	62.5	11	35x10	7.95	2

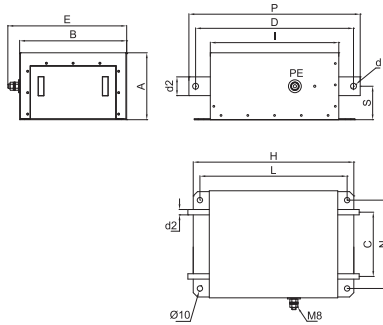
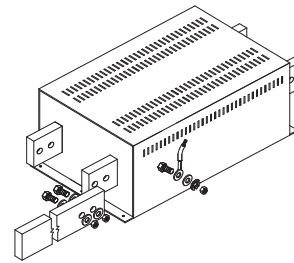
**CASE 1, 2**

**ASSEMBLY CONNECTION "B"**

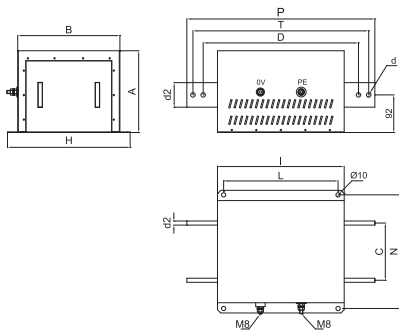
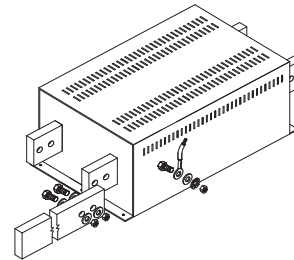
**MECHANICAL DIMENSIONS mm**

FIN7212	A	B	C	D	E	H	I	L	N	P	S	T	d	d2	Weight Kg.	Case
.800.B	200	250	140	380	277	300	310	280	278	460	-	430	11	50x10	5	3
.900.B	200	250	140	380	277	300	310	280	278	460	-	430	11	50x10	15	3
.1000.B	200	250	140	380	277	300	310	280	278	460	-	430	11	60x10	16	4
.1250.B	200	250	140	380	277	300	310	280	278	460	-	430	11	60x10	17	4

**CASE 3, 4**

**ASSEMBLY CONNECTION "B"**

**MECHANICAL DIMENSIONS mm**

FIN7212	A	B	C	D	H	I	L	N	P	K	T	d2	Weight Kg.	Case
.1500.B	200	250	140	380	300	310	280	278	460	430	405	70x10	19	5

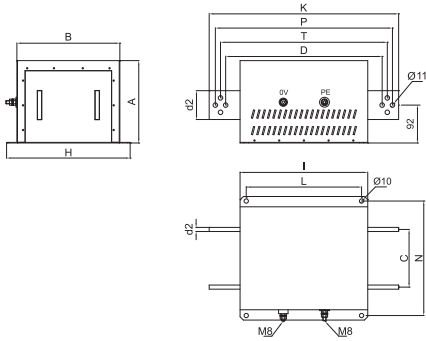
**CASE 5**



**ASSEMBLY CONNECTION "B"**

