

Introduction

The operation of motors under the control of variable frequency drives (VFDs) or servo drives demands careful consideration to prevent overvoltage spikes, commonly referred to as dV/dt . The occurrence of voltage wave reflection is intricately tied to the voltage rise time (dV/dt) and the length of the motor cables. This phenomenon introduces additional overvoltage spikes, leading to premature degradation and potential failure of the motor insulation.

Meeting the challenge of safeguarding motors against overvoltage is crucial for Original Equipment Manufacturers (OEMs), system integrators, and distributors. Industries utilizing VFDs have embraced a specialized motor category

known as a motor rated VFD or inverter duty motor.

The construction of a motor rated VFD can vary significantly among manufacturers. However, adhering to the guidelines of the National Electrical Manufacturer's Association (NEMA), the primary distinction between a standard motor and an inverter duty motor lies in the winding insulation.

As an illustration, consider a nominal 480 Vac AC drive utilizing a standard-grade motor, which should maintain performance and function with peak voltage up to 1000V. In contrast, for inverter duty-rated motors, the acceptable peak voltage typically extends to 1500V.

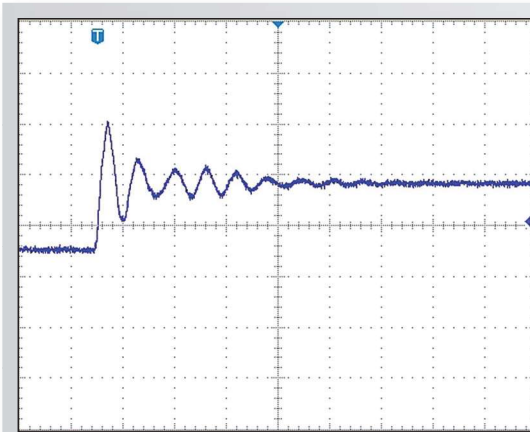

Typical example of dV/dt measured on the motor with cable length of 50m (150 ft)

Theory

To gain a comprehensive understanding of the factors leading to motor failure and unforeseen challenges, it's essential to understand the construction of a VFD. They consist of three major components:

- The rectifier - transforms incoming AC power into DC power
- The DC link - incorporates multiple capacitors for storing energy from the rectifier's output
- The inverter - generates a 2-20 kHz signal, utilizing pulse width modulation to produce the output waveform directed to the motor

Pulse Width Modulation (PWM) is a technique that adjusts the width of a pulse based on modulation signal information. This technique introduces a notable concern related to dV/dt within the system.

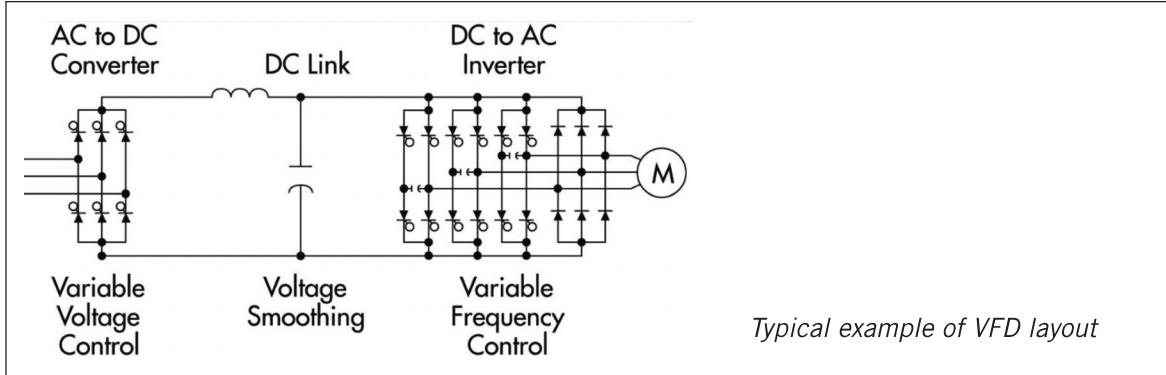

The Solution

Enerdoor presents its Motor Protection Series, specifically crafted to shield motors from detrimental overvoltage and dV/dt spikes emanating from the drive's output. This solution is particularly valuable for applications involving variable frequency drives and servo drives.

Enerdoor's array of solutions encompasses common mode and differential mode chokes, sine wave filters, and snubbers—all meticulously designed to seamlessly integrate with diverse carrier frequencies, output frequencies, and applications.

Specific Solutions

Sine Wave Filters: This specialized series mitigates the impact of PWM by transforming the drive's output into an authentic sine waveform, effectively eliminating dV/dt.

The **FIN915SF** model is specifically designed for applications with fundamental frequencies reaching up to 25 kHz.

The **FIN960F** high-frequency inductance caters to synchronous motor spindle applications, offering a unique approach to handling output frequencies spanning from 1 Hz to 10 kHz.

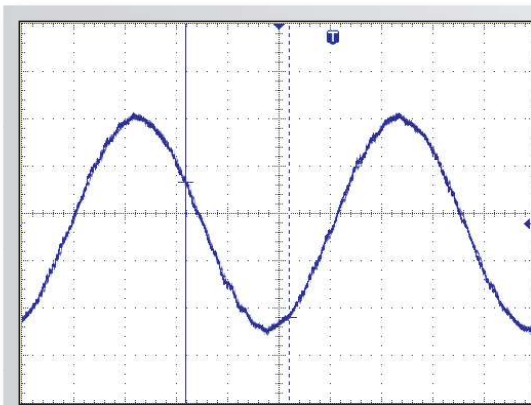

Typical example of a waveform between the VFD and motor using an Enerdoor sine wave filter FIN915SFH



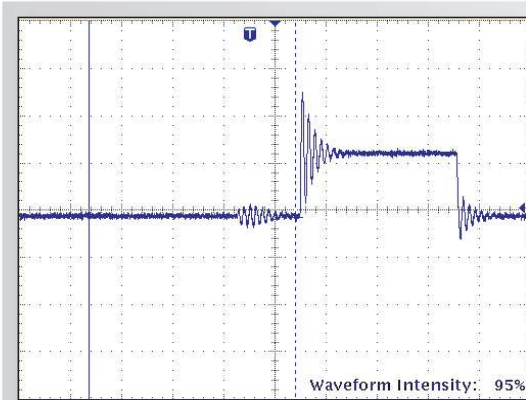

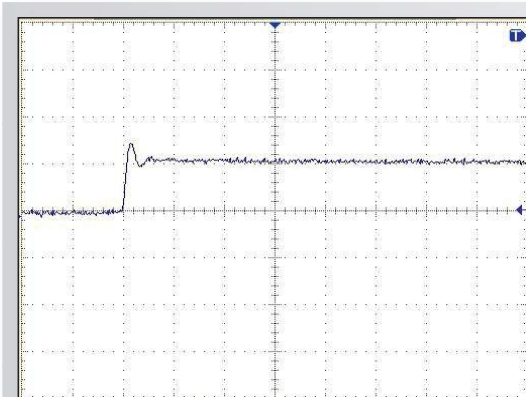

The Enerdoor Snubber (**FIN47SNB**) – is a distinctive solution engineered to minimize both common mode and differential mode noise. This specialized snubber operates in parallel with the system, offering an ideal remedy for clients seeking to enhance the reliability of winding insulation and bearings.



Typical measurement of dV/dt on the motor side of VFD with cable length of 100m (300ft)



Typical measurement of dV/dt on the motor side of VFD with cable length of 100m (300ft) with Enerdoor snubber FIN47SNB installed

Filter Selection Guide	Description	Current Range (A)	Voltage	CONNECTORS				FEATURES					APPLICATIONS				Approval	
				Cables	Terminal Blocks	Screws	Bus Bar	Common Mode Attenuation	Differential Mode Attenuation	Very Long Cable Applications	Output Frequency >75Hz	Compact Case	Long Cable Application >300m	CNC Machine	High Frequency Spindle Motor	Motor Controlled by VFD <100m		Closed Loop Motor Application
Motor Protection																		
FIN900	3-phase	10-280	0-600	•	•	•		•				•		•		•		
FIN930	3-phase	6-200	0-600		•			•										•
ORT	3-phase	2-1000	0-480		•		•	•								•		
FIN5955	3-phase	3-20	0-600		•			•			•		•		•			
FIN958	3-phase	12-110	0-600		•			•		•	•	•	•	•				•
FIN5980P	3-phase	9-22	0-480	•	•									•				
FIN5983	3-phase	12-60	0-600		•							•	•					
FIN960F	3-phase	10-1000	0-750		•			•		•			•	•				
FVT	3-phase	2-1000	0-690		•		•	•	•		•							
SWF	3-phase	2-1000	0-690		•		•	•	•		•							
FIN915SFH	3-phase	5-1100	0-600		•			•	•	•					•			
FIN47SNB	3-phase plus neutral	unlimited	0-600		•					•	•	•				•	•	
FINSTP	star point to ground	unlimited	0-600		•					•	•	•	•			•	•	
FINTR	-	-	-															
FINFE	-	-	-															

The Enerdoor Motor Protection Series provides safeguarding against overvoltage and dV/dt spikes originating from drive outputs, particularly vital for applications involving variable frequency drives (VFDs), servo drives, and long cable runs.

This comprehensive series offers a range of output filters meticulously designed to seamlessly integrate with various carrier frequencies, output frequencies, and applications. It includes load reactors (differential mode inductance), dV/dt filters, sine wave filters, high-frequency inductance filters, and snubbers and chokes (common mode inductance).

A standout component in this series is the sine wave filter SWF, which effectively transforms PWM into a sine wave, reducing dV/dt. Additionally, the FIN960F high-frequency inductance serves as a specialized solution for synchronous spindle motor applications, supporting frequency outputs of up to 30 kHz.

With CE and UL approvals, the series features a current range from 2 to 1100 A, offering exceptional attributes such as high linearity versus frequency and current, remarkably low operating temperatures, and compact dimensions.

Motor protection applications include:

- Motors controlled by drives
- Pumps and conveyors
- Automated machinery
- Closed-loop motor applications
- High-speed motors
- CNC machinery
- Long cable applications (up to 2,500m or 8,200 ft)
- Process plants
- Water treatment plants
- Packaging machinery

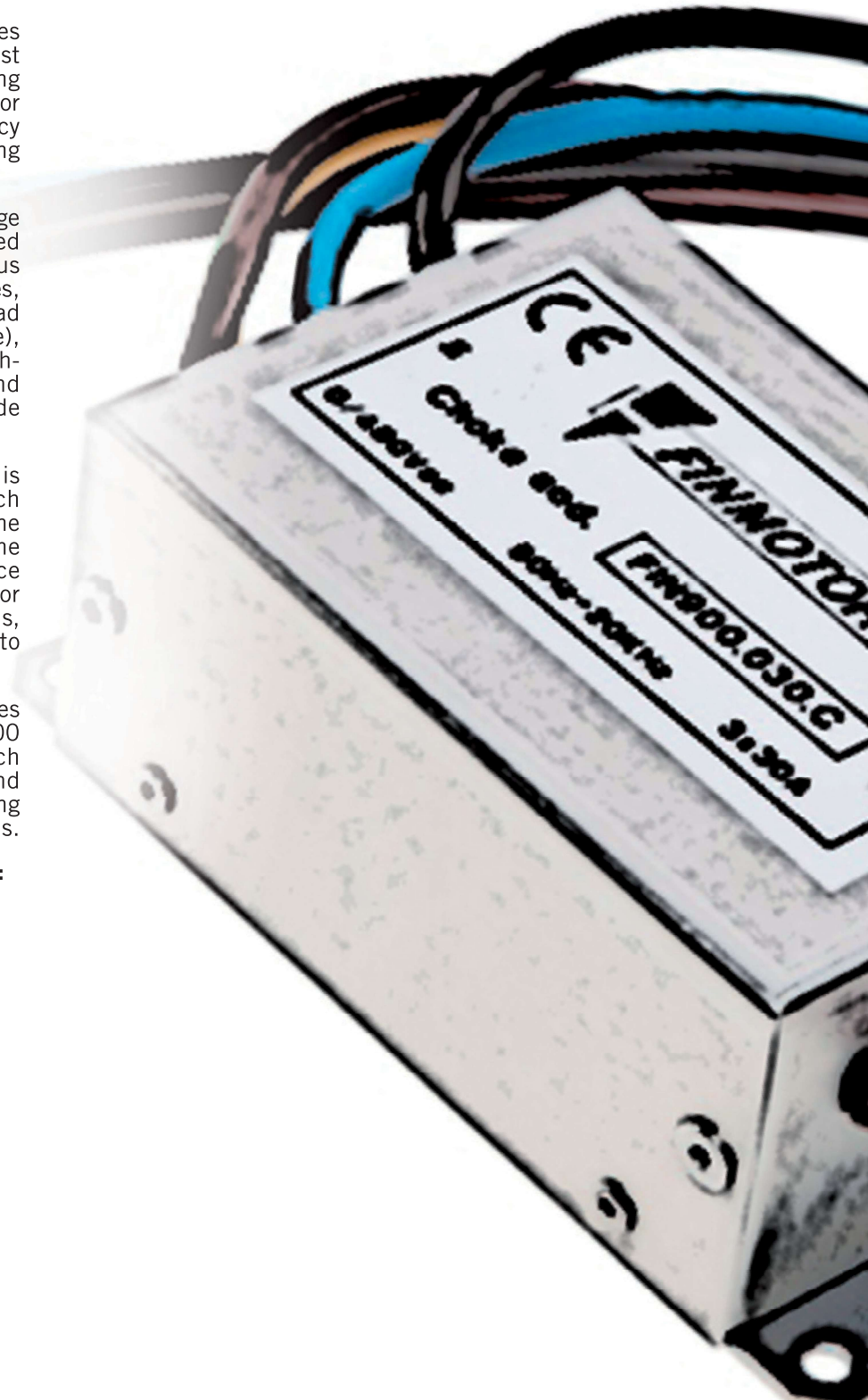



Datasheet 202405

Common mode choke with high attenuation for reducing dV/dt and high frequency

APPROVALS:



FIN900.(010 - 030).1C

FEATURES

- 5 Year warranty
- Protects against voltage spikes on the motor
- Compact design

BENEFITS

- Rated current from 10 to 280A
- Reduces voltage rise and high frequency noise
- Helps pass emission tests for the IEC61000-6-4 Standards



FIN900.(010 - 030).C

MARKETS

- Motors controlled by drives
- Automated machinery
- Conveyors
- Pumps

ORDERING CODE

FIN900	.016	.1C
Model	Current (A)	Connection
		1 C = cable 200mm
		2 C = cable 400mm
		C = cable
		V = screws



FIN900.(010 - 280).V

ATTENUATION INDICATOR



ELECTRIC DIAGRAM

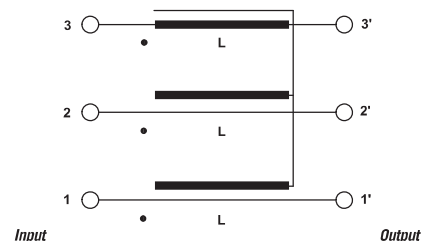

TECHNICAL SPECIFICATIONS

Nominal voltage	0 - 600 Vac
Output frequency	50 - 3500 Hz
Rated current	10 - 280 A
Carrier frequency (PWM)	0 - 16 kHz
Potential test voltage phase to phase	1750 Vdc (2 sec.)
Potential test voltage phase to ground	2150 Vdc (2 sec.)
IP Protection	IP20
Overload capability	4 x Rated current (Switch ON) 2 x In 10 seconds 1.5 In for 10 minutes
Climatic class	-40 to 85°C
MTBF at 40°C	250,000 Hours

ELECTRICAL CHARACTERISTICS

FIN900	Rated Current 40°C	Rated Current 50°C	Power Loss (W)
.010.1C	10	9	6
.016.1C	16	14	6
.030.1C	30	26	6

CONNECTIONS

LINE		PE	
d (mm)	Torque (Nm)	d1 (mm)	Torque (Nm)
-	-	M12	20
-	-	M12	20
-	-	M12	20

TYPICAL MEASUREMENT

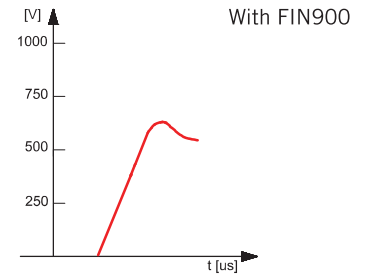
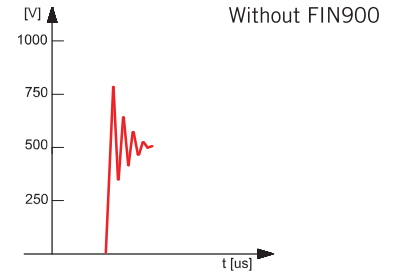

Example of measurement in a typical application using a servo drive

FIN900	Rated Current 40°C	Rated Current 50°C	Power Loss (W)
.010.C	10	9	6
.016.C	16	14	6
.030.C	30	26	6

LINE		PE	
d (mm)	Torque (Nm)	d1 (mm)	Torque (Nm)
-	-	-	-
-	-	-	-
-	-	-	-

FIN900	Rated Current 40°C	Rated Current 50°C	Power Loss (W)
.010.V	10	9	6
.016.V	16	14	10
.030.V	30	26	15
.050.V	50	45	23
.080.V	80	72	28
.100.V	100	90	45
.150.V	150	135	75
.200.V	200	180	83
.280.V	280	252	96

LINE		PE	
d (mm)	Torque (Nm)	d1 (mm)	Torque (Nm)
M4	1.2	M4	1.2
M5	4	M4	1.2
M5	4	M4	1.2
M6	6	M5	4
M6	6	M5	4
M8	14	M8	14
M8	14	M8	14
M10	18	M10	18
M12	18	M10	18

MECHANICAL DIMENSIONS mm

FIN900	A	B	d	V	d1	H	Weight Kg.	Case
.010.1C	60	65	2	12	M12	200	0.5	1C
.016.1C	60	65	2	12	M12	200	0.5	1C
.030.1C	60	65	2	12	M12	200	0.55	1C

CASE 1C

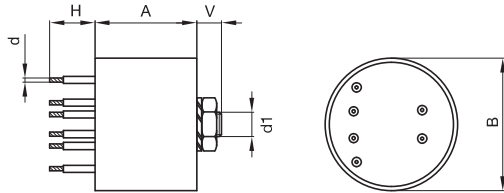

ASSEMBLY CONNECTION "1C"

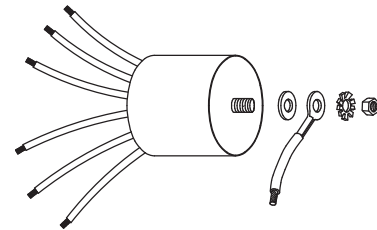

FIN900	A	B	d	V	F	H	I	L	N	Weight Kg.	Case
.010.C	42	65	2	200	4.2	120	96	110	51	0.7	C
.016.C	42	65	2	200	4.2	120	96	110	51	0.7	C
.030.C	42	65	2	200	4.2	120	96	110	51	0.75	C

CASE C

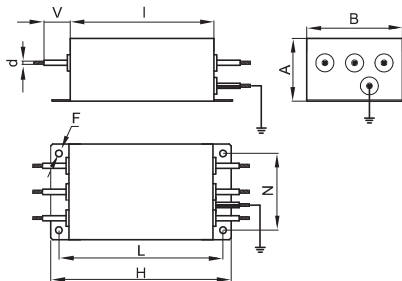

ASSEMBLY CONNECTION "C"

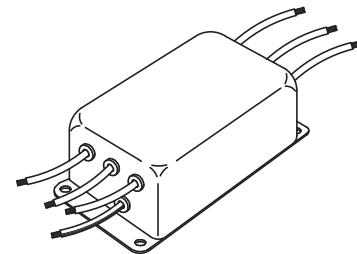

MECHANICAL DIMENSIONS mm

FIN900	A	B	C	d	d1	V	F	H	I	L	N	P	S	Weight Kg.	Case
.010.V	58	86	44	M4	M4	14	4.5	186	160	176	30	40	38	2	1
.016.V	58	86	44	M5	M4	14	4.5	186	160	176	30	40	38	2	1
.030.V	58	86	44	M5	M4	14	4.5	186	160	176	30	40	38	2	1
.050.V	58	86	44	M6	M5	14	4.5	186	160	176	30	40	38	2	1
.080.V	90	100	46	M6	M5	28	4.5	246	220	235	35	70	64	3	2
.100.V	90	185	84	M8	M8	25	6.5	356	320	340	77.5	70	69	5	3
.150.V	90	220	120	M8	M8	29	6.5	356	320	340	95	70	60	7	4
.200.V	90	220	120	M10	M10	29	6.5	356	320	340	95	70	60	7.5	4
.280.V	90	220	120	M12	M10	29	6.5	356	320	340	95	70	60	8	4

CASE 1, 2

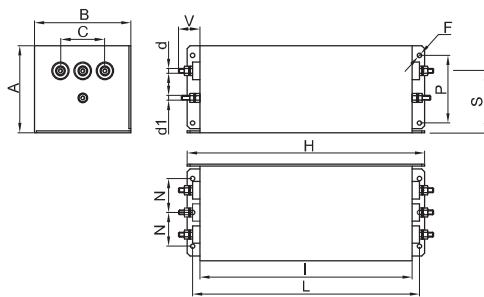

ASSEMBLY CONNECTION "V"

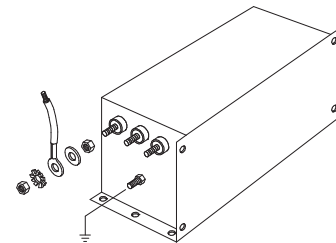

CASE 3, 4

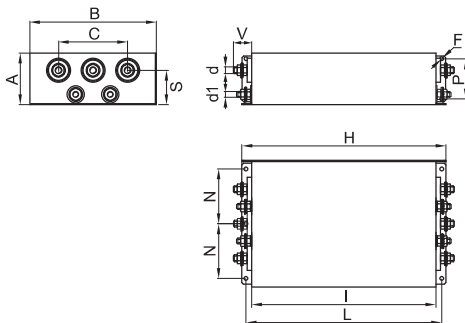

ASSEMBLY CONNECTION "V"

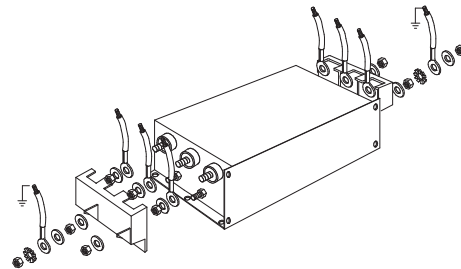



Common mode choke with very high attenuation for reducing dV/dt

Datasheet 202405

APPROVALS:



FIN930.(006 - 200).M

FEATURES

- Rated current from 6 - 200 A
- Increases motor life
- Protects against voltage spikes on the motor

BENEFITS

- 5 Year warranty
- Safety terminal block connectors
- Helps pass immunity and emission tests for the IEC61000-6-2 and IEC61000-6-4 Standards

MARKETS

- Motors controlled by drives
- Pumps
- Conveyors
- Spindle motors closed loop

ORDERING CODE

FIN930	.055	.M
Model	Current (A)	Connection
		M = Terminal block

ATTENUATION INDICATOR

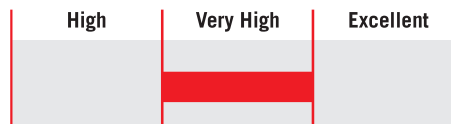

ELECTRIC DIAGRAM

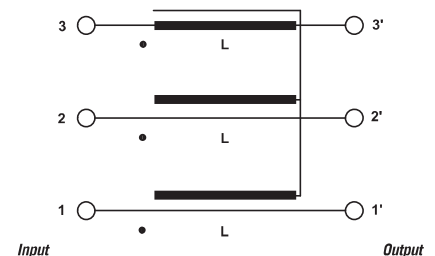

TECHNICAL SPECIFICATIONS

Nominal voltage	0 - 600 Vac
Output frequency	50 - 3500 Hz
Rated current	6 - 200 A
Carrier frequency (PWM)	0 - 16 kHz
Potential test voltage phase to phase	2400 Vdc (2 sec.)
Potential test voltage phase to ground	3200 Vdc (2 sec.)
IP Protection	IP20
Overload capability	4 x Rated current (Switch ON) 2 x In 10 seconds 1.5 In for 10 minutes
Climatic class	-40 to 85°C
MTBF at 40°C	250,000 Hours

ELECTRICAL CHARACTERISTICS

FIN930	Rated Current 40°C	Rated Current 50°C	Power Loss (W)
.006.M	8	6	3
.012.M	14	12	3
.016.M	18	16	4
.025.M	28	25	4
.032.M	35	32	5
.042.M	50	42	7
.055.M	63	55	8
.070.M	80	70	13
.080.M	90	80	13
.100.M	110	100	15
.115.M	130	115	22
.150.M	175	150	25
.200.M	230	200	28

CONNECTIONS

LINE			PE	
Solid Cable (mm ²)	Stranded Cable (mm ²)	Terminal Torque (Nm)	d (mm)	Torque (Nm)
0.2 - 10	0.2 - 6	1.2	M6	1.2
0.2 - 10	0.2 - 6	1.2	M6	1.2
0.2 - 10	0.2 - 6	1.2	M6	1.2
0.2 - 10	0.2 - 6	1.2	M6	1.2
0.2 - 10	0.2 - 6	1.2	M6	1.2
0.5 - 16	0.5 - 10	1.8	M6	1.8
0.5 - 16	0.5 - 10	1.8	M6	1.8
4 - 25	6 - 35	4.5	M10	4.5
4 - 25	6 - 35	4.5	M10	4.5
10 - 50	10 - 50	4	M10	4
10 - 50	10 - 50	4	M10	4
35 - 95	35 - 95	20	M10	20
35 - 95	35 - 95	20	M10	20

TYPICAL MEASUREMENT

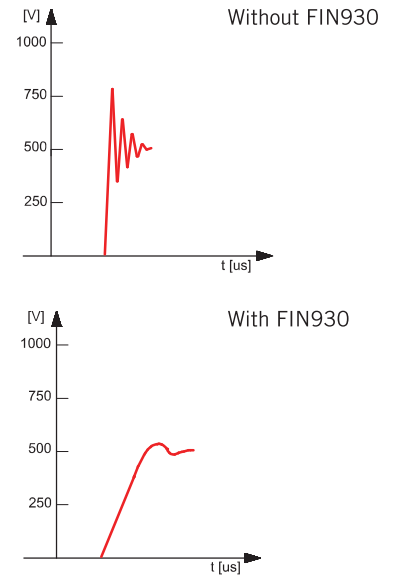

Example of measurement in a typical application using a servo drive

MECHANICAL DIMENSIONS mm

FIN930	A	B	V	V1	F	H	I	L	N	d	Weight Kg.	Case
.006.M	140	50	19	15	6	226	200	7	28	M6	1.7	1
.012.M	140	50	19	15	6	226	200	7	28	M6	1.7	1
.016.M	177	60	19	15	6	267	237	8	34	M6	1.7	1
.025.M	177	60	19	15	6	267	237	8	34	M6	2.3	1
.032.M	177	60	19	15	6	267	237	8	34	M6	2.3	1
.042.M	177	70	19	25	6	295	265	8	44	M6	3.4	1
.055.M	177	70	19	33	6	295	265	8	44	M6	3.5	1
.070.M	205	80	28	38	8	390	340	12	53	M10	6	1
.080.M	205	80	28	38	8	390	340	12	53	M10	6	1
.100.M	205	80	28	43	8	390	340	12	53	M10	7.1	1
.115.M	205	80	28	43	8	390	340	12	53	M10	7.1	1
.150.M	220	105	28	50	8	420	370	12	78	M10	8.5	1
.200.M	220	105	28	50	8	420	370	12	78	M10	8.5	1

CASE 1

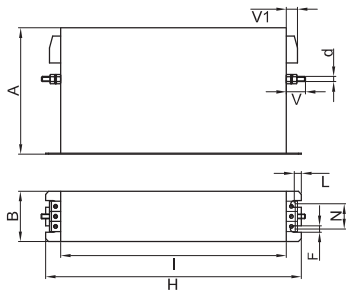

ASSEMBLY CONNECTION "M"

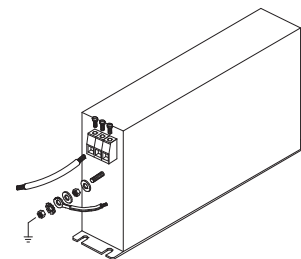

ELECTRICAL CHARACTERISTICS			MECHANICAL DIMENSIONS mm										CONNECTIONS			
ORT	Rated Current 40°C	Power Loss (W)	A	B	C	D	E	F	G	H	Weight (Kg.)	Case	LINE		PE	
													Cable (mm ²)	Terminal Torque (Nm)	Cable (mm ²)	Terminal Torque (Nm)
ORT025.0002452MXXA	2	6	150	98	185	125	56	6	13	73	3	1	0.5-4	0.8	0.5-4	0.8
ORT025.0004452MXXA	4	8	150	98	185	125	56	6	13	73	3	1	0.5-4	0.8	0.5-4	0.8
ORT025.0006452MXXA	6	11	150	98	185	125	56	6	13	73	3	1	0.5-4	0.8	0.5-4	0.8
ORT025.0008452MXXA	8	13	150	98	185	125	56	6	13	73	3	1	0.5-4	0.8	0.5-4	0.8
ORT025.0012452MXXA	12	19	150	98	185	125	56	6	13	73	3.5	1	0.5-4	0.8	0.5-4	0.8
ORT025.0016452MXXA	16	24	150	98	189	125	56	6	13	73	3.5	1	0.5-6	1.8	0.5-6	1.8
ORT025.0020452MXXA	20	26	150	103	189	125	61	6	13	78	5	1	0.5-6	1.8	0.5-6	1.8
ORT025.0025452MXXA	25	27	150	118	193	125	71	6	13	88	6.5	1	0.5-10	1.8	0.5-10	1.8
ORT025.0032452MXXA	32	33	150	118	193	125	71	6	13	88	6.5	1	0.5-10	1.8	0.5-10	1.8
ORT030.0038452MXXA	38	43	180	130	231	150	72	8	20	100	8	1	1.5-16	3.4	1.5-16	3.4
ORT030.0045452MXXA	45	47	180	140	231	150	82	8	20	110	8	1	1.5-16	3.4	1.5-16	3.4
ORT030.0060452MXXA	60	52	180	150	231	150	92	8	20	120	12	1	1.5-16	3.4	1.5-16	3.4
ORT030.0075452MXXA	75	57	180	150	231	150	92	8	20	120	12	1	1.5-16	3.4	1.5-16	3.4
ORT030.0090452MXXA	90	65	180	175	239	150	107	8	20	135	12	1	16-50	5.6	1.5-35	6.5
ORT040.0110452MXXA	110	84	240	170	302	200	87	8	20	119	19	1	16-50	5.6	1.5-35	6.5
ORT040.0130452MXXA	130	78	240	190	309	200	97	8	20	129	24.5	1	35-95	10	16-50	5.6
ORT040.0150452MXXA	150	87	240	210	309	200	117	8	20	149	28	1	35-95	10	16-50	5.6
ORT040.0180452MXXA	180	97	240	210	309	200	117	8	20	149	28	1	35-95	10	16-50	5.6

ELECTRICAL CHARACTERISTICS			MECHANICAL DIMENSIONS mm													CONNECTIONS				
ORT	Rated Current 40°C	Power Loss (W)	A	B	C	D	E	F	G	H	I	M	J	K	X	Y	Weight (Kg.)	Case	LINE	PE
																			Torque (Nm)	Screw (mm)
ORT050.0210452BXXA	210	102	300	180	295	260	103	8	26	143	11				30	6	34	2	25	8x25
ORT050.0260452BXXA	260	126	300	187	295	260	103	8	26	153	13				40	6	34	2	50	8x25
ORT050.0320452BXXA	320	112	300	227	295	260	113	8	26	153	13	20	20		50	6	52	3	50	8x25
ORT050.0380452BXXA	380	126	300	245	295	260	113	8	26	155	13	14	20		40	10	55	3	50	8x25
ORT060.0440452BXXA	440	138	360	240	345	260	115	8	26	155	13	14	20	15	50	10	71	3	50	8x25
ORT060.0500452BXXA	500	160	360	240	345	260	115	8	26	155	13	20	20	15	50	10	73	3	50	8x25
ORT060.0600452BXXA	600	195	360	257	345	260	145	8	26	185	13	20	20	15	50	10	95	3	50	8x25
ORT080.0700452BXXA	700	234	480	317	459	360	154	10	30	200	13	20	20	20	60	10	102	3	50	10x35
ORT080.0800452BXXA	800	286	480	352	459	360	184	10	30	230	13	40	40	20	80	10	165	3	50	10x35
ORT080.0900452BXXA	900	318	480	370	459	360	214	10	30	260	13	40	40	20	80	10	235	3	50	10x35
ORT080.1000452BXXA	1000	347	480	370	459	360	214	10	30	260	13	40	40	20	80	10	236	3	50	10x35

CASE 1

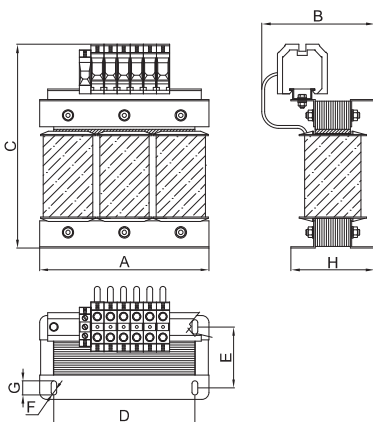

CASE 2

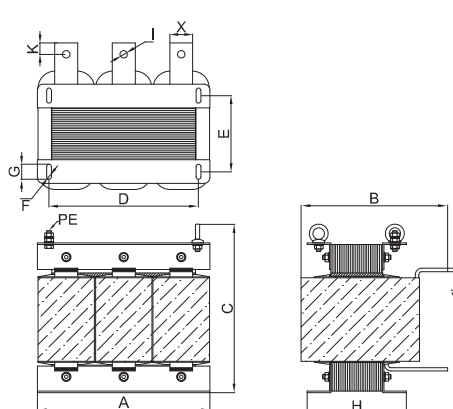

CASE 3

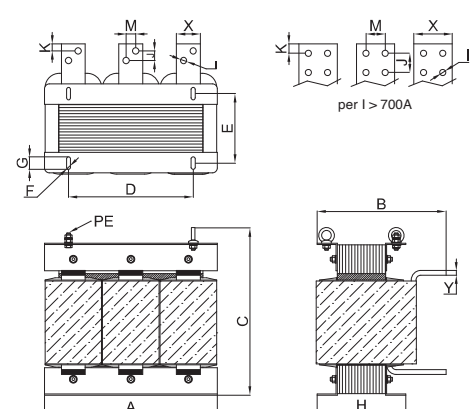



Datasheet 202405

High frequency differential choke with excellent attenuation to reduce dV/dt

APPROVALS:



FIN955.(003 - 020).M

FEATURES

- Rated current from 3 to 20A
- Increases motor life
- Protects against voltage spikes on the motor
- Low power loss up to 250 Hz frequency output

BENEFITS

- 2 Year warranty
- Safety terminal block connectors
- Very compact design

MARKETS

- High speed motors up to 250 Hz
- AC motors controlled by VFDs
- Woodworking machinery
- Spindle motors closed loop

ORDERING CODE

FIN955	.020	.M
Model	Current (A)	Connection
		M = Terminal block

ATTENUATION INDICATOR

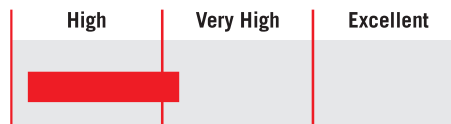

ELECTRIC DIAGRAM

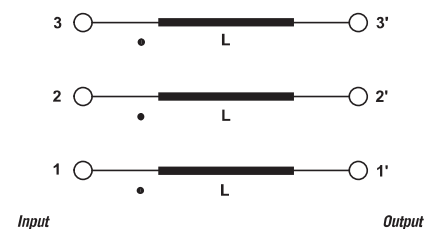

TECHNICAL SPECIFICATIONS

Nominal voltage	0 - 600 Vac
Output frequency	0 - 250 Hz*
Rated current	3 - 20 A
Carrier frequency (PWM)	0 - 16 kHz
Potential test voltage phase to phase	2400 Vdc (2 sec.)
Potential test voltage phase to ground	3200 Vdc (2 sec.)
IP Protection	IP20
Saturation current	4 x Rated current (Switch ON) 2 x In 10 seconds 1.5 In for 10 minutes 1.5 x Nominal current
Climatic class	-40 to 85°C
MTBF at 40°C	250,000 Hours.

* Optional output frequency 850 Hz

ELECTRICAL CHARACTERISTICS

FIN955	Rated Current 40°C	Rated Current 50°C	Power Loss (W)
.003.M	3	2	2.2
.006.M	6	5	2.4
.010.M	10	8	2.7
.020.M	20	17	3

CONNECTIONS

LINE			PE	
Solid Cable (mm ²)	Stranded Cable (mm ²)	Terminal Torque (Nm)	V (mm)	Torque (Nm)
0.2 - 6	0.2 - 6	1.2	M4	1.2
0.2 - 6	0.2 - 6	1.2	M4	1.2
0.2 - 6	0.2 - 6	1.2	M4	1.2
0.2 - 6	0.2 - 6	1.2	M4	1.2

TYPICAL MEASUREMENT

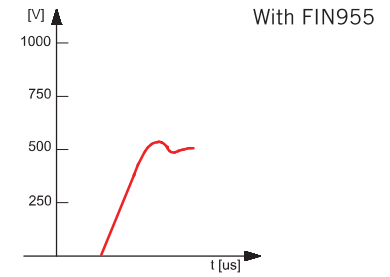
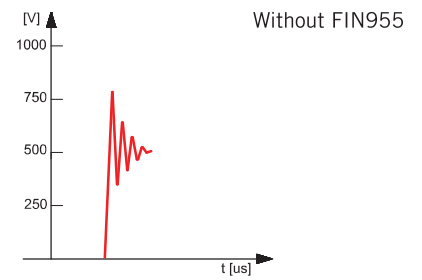

Example of measurement in a typical application using a servo drive

MECHANICAL DIMENSIONS mm

FIN955	A	B	C	D	H	N	I	V	Weight Kg.	Case
.003.M	60	101	125	113	51	11	4x17	M4	0.40	1
.006.M	60	101	125	113	51	11	4x17	M4	0.40	1
.010.M	60	101	125	113	51	11	4x17	M4	0.45	1
.020.M	60	101	125	113	51	11	4x17	M4	0.45	1

CASE 1

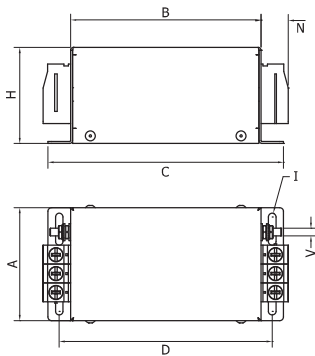

ASSEMBLY CONNECTION "M"

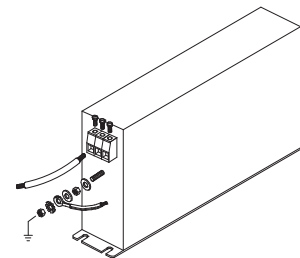

ELECTRICAL CHARACTERISTICS

FIN958	Rated Current 40°C	Rated Current 50°C	Power Loss (W)
.012.M	12	10	3.4
.020.M	20	18	4.4
.025.M	25	23	4.8
.032.M	32	28	5.3
.042.M	42	38	7
.060.M	60	54	11
.075.M	75	67	12
.090.M	90	81	12.7
.110.M	110	100	13

CONNECTIONS

LINE			PE	
Solid Cable (mm ²)	Stranded Cable (mm ²)	Terminal Torque (Nm)	d (mm)	Torque (Nm)
0.5 - 10	0.5 - 10	1.2	M6	1.2
0.5 - 10	0.5 - 10	1.2	M6	1.2
0.5 - 10	0.5 - 10	1.2	M6	1.2
0.5 - 10	0.5 - 10	1.2	M6	1.2
0.5 - 10	0.5 - 16	1.2	M6	1.2
6 - 16	10 - 35	4.5	M6	6
6 - 16	10 - 35	4.5	M6	6
16 - 50	16 - 50	4.0	M10	6
35 - 95	35 - 95	20.0	M10	6

TYPICAL MEASUREMENT

Without FIN958

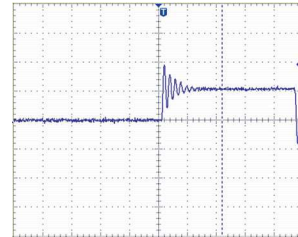

With FIN958

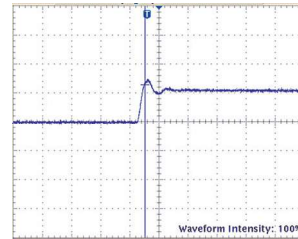

Example of measurement in a typical application using a servo drive

MECHANICAL DIMENSIONS mm

FIN958	A	B	V	V1	F	H	I	L	N	d	Weight Kg.	Case
.012.M	100	90	22	16	5.4	250	220	7.5	60	M6	1.9	1
.020.M	100	90	22	16	5.4	250	220	7.5	60	M6	1.9	1
.025.M	100	90	22	16	5.4	250	220	7.5	60	M6	1.9	1
.032.M	100	90	22	16	5.4	250	220	7.5	60	M6	2.0	1
.042.M	100	90	22	35	5.4	250	220	7.5	60	M6	2.5	2
.060.M	135	85	22	39	6.5	270	240	7.5	60	M6	3.8	3
.075.M	135	85	22	39	6.5	270	240	7.5	60	M6	4.5	3
.090.M	155	90	24	43	6.5	270	240	7.5	65	M10	6.0	3
.110.M	170	125	26	51	6.5	380	350	7.5	102	M10	8.5	4

CASE 1, 2, 3, 4

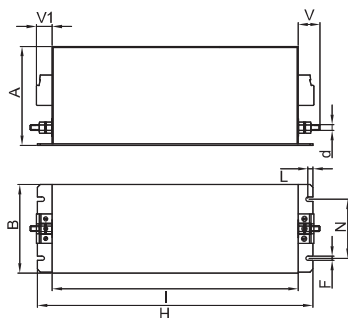

ASSEMBLY CONNECTION "M"

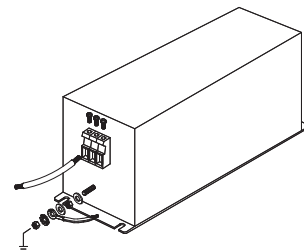



Datasheet 202405

High frequency differential choke with excellent attenuation to reduce dV/dt

APPROVALS:



FIN980P.(009 - 022).M

FEATURES

- Rated current from 9 to 22A
- Increases motor life
- Protects against voltage spikes on the motor

BENEFITS

- Overvoltage spikes regenerate into the DC bus
- Safety terminal block connectors
- Low power loss up to 1.5 kHz frequency output

MARKETS

- Servo drives
- Spindle motors
- Closed loop motor applications

ORDERING CODE

FIN 980P .022 .M
Model Current (A) Connection
M = Terminal block

ATTENUATION INDICATOR



ELECTRIC DIAGRAM

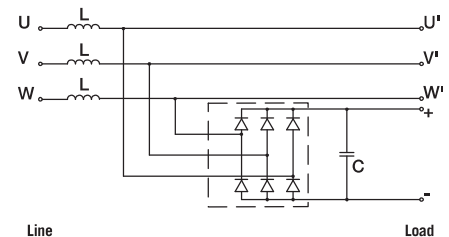

TECHNICAL SPECIFICATIONS

Nominal voltage	0 - 480 Vac
Output frequency	1 - 1500 Hz
Rated current	9 - 22 A
Carrier frequency (PWM)	0 - 16 kHz
Potential test voltage phase to phase	1200 Vdc (2 sec.)
Potential test voltage phase to ground	3200 Vdc (2 sec.)
IP Protection	IP20
Saturation current	4 x Rated current (Switch ON) 2 x In 10 seconds 1.5 In for 10 minutes 1.5 x Nominal current
Climatic class	-40 to 85°C
MTBF at 40°C	250,000 Hours.

ELECTRICAL CHARACTERISTICS

FIN980P	Rated Current 40°C	Rated Current 50°C	Power Loss at 50 Hz (1000 Hz)
.009.M	12	10	1.2 (2.7)
.022.M	30	25	1.8 (4.7)

CONNECTIONS

Solid Cable (mm ²)	LINE		PE
	Stranded Cable (mm ²)	Terminal Block Torque (Nm)	Torque (Nm)
0.5 - 16	0.5 - 10	1.8	1.8
0.5 - 16	0.5 - 10	1.8	1.8

MECHANICAL DIMENSIONS mm

FIN980P	A	B	C	D	E	F	H	I	L1	L2	N	Weight Kg.	Case
.009.M	60	295	345	330	220	280	60	5	300	300	11	2.2	1
.022.M	100	295	345	330	76	280	100	5	300	300	11	3	2

CASE 1

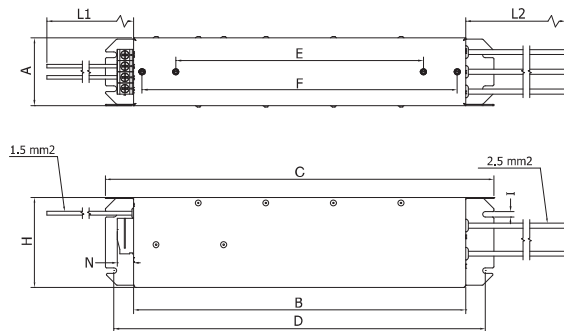

CASE 2

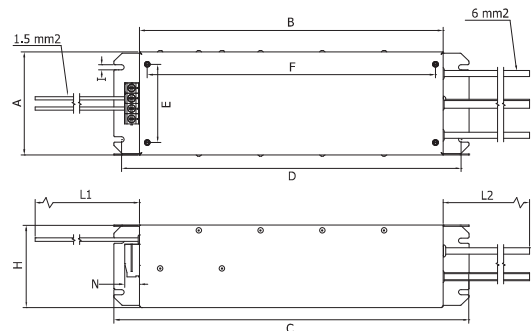



**High frequency differential choke
with excellent attenuation to
reduce dV/dt**

Datasheet 202405

APPROVALS:



FIN983.(012 - 060).M

FEATURES

- Rated current from 12 to 60A
- Increases motor life
- Protects against voltage spikes on the motor

BENEFITS

- Safety terminal block connectors
- Low power loss up to 1 kHz frequency output

MARKETS

- Motors controlled by drives
- Woodworking machinery
- Closed loop motor applications

ORDERING CODE

FIN 983 .030 .M
Model Current (A) Connection
M = Terminal block

ATTENUATION INDICATOR



ELECTRIC DIAGRAM

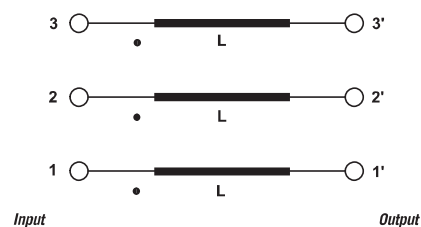

TECHNICAL SPECIFICATIONS

Nominal voltage	0 - 600 Vac
Output frequency	0 - 1000 Hz
Rated current	12 - 60 A
Carrier frequency (PWM)	0 - 16 kHz
Potential test voltage phase to phase	2400 Vdc (2 sec.)
Potential test voltage phase to ground	3200 Vdc (2 sec.)
IP Protection	IP20
Saturation current	4 x Rated current (Switch ON) 2 x In 10 seconds 1.5 In for 10 minutes 1.5 x Nominal current
Climatic class	-40 to 85°C
MTBF at 40°C	250,000 Hours.

ELECTRICAL CHARACTERISTICS

FIN983	Rated Current 40°C	Rated Current 50°C	Power Loss (W)
.012.M	12	10	1.2 (2.7)
.030.M	30	25	1.8 (4.7)
.040.M	45	37	3 (7)
.060.M	60	50	8 (16.8)

CONNECTIONS

LINE			PE
Solid Cable (mm ²)	Stranded Cable (mm ²)	Terminal Torque (Nm)	Torque (Nm)
0.5 - 16	0.5 - 10	1.8	1.8
0.5 - 16	0.5 - 10	1.8	1.8
0.5 - 16	0.5 - 10	1.8	1.8
4 - 25	6 - 35	4.5	4.5

TYPICAL MEASUREMENT

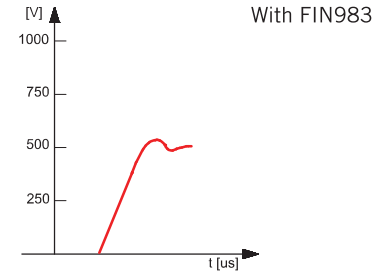
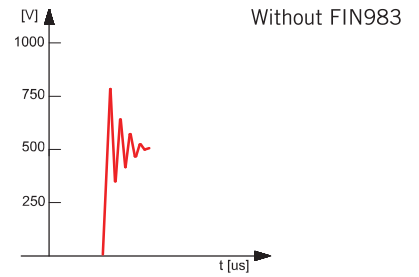

Example of measurement in a typical application using a servo drive

MECHANICAL DIMENSIONS mm

FIN983	A	B	C	D	E1	E2	F	G	H	J	L	I	N	Weight Kg.	Case
.012.M	140	295	345	330	14	76	280	80	80	50	300	5	33	2.2	1
.030.M	140	295	345	330	14	76	280	80	80	50	300	5	33	2.5	1
.040.M	200	295	345	330	-	160	280	120	80	50	300	5	38	3.2	1
.060.M	200	295	345	330	-	160	280	120	80	50	300	5	38	4	1

CASE 1

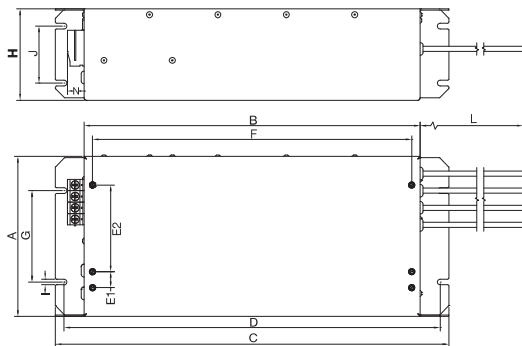

ASSEMBLY CONNECTION "M"

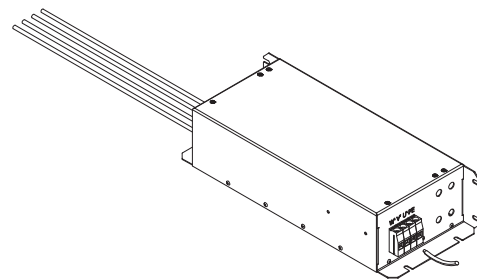



Datasheet 202405

High frequency differential mode choke with excellent attenuation for high speed motors

APPROVALS:



FIN960F.(010 - 1000).M

FEATURES

- Rated current from 10 to 1000A
- Increases motor life
- Protects against voltage spikes on the motor
- Customizable per motor specifics to optimize the system

BENEFITS

- Low power loss with frequency output up to 30 kHz
- No ventilation required
- Excellent performance versus frequency and current
- Available in open frame or enclosure

MARKETS

- High speed motors
- CNC machinery
- Woodworking machinery

ORDERING CODE

FIN960F	.050	.M	010
Model	Current (A)	Connection	Inductance value (L)
		M = Terminal block	

ATTENUATION INDICATOR



ELECTRIC DIAGRAM

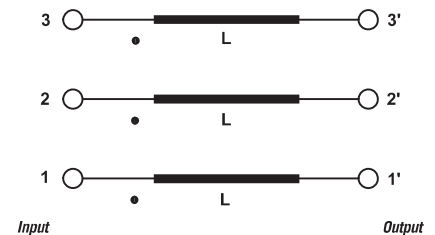

TECHNICAL SPECIFICATIONS

Nominal voltage	0 - 750 Vac
Output frequency	0 - 30 kHz
Rated current	10 - 1000 A
Carrier frequency (PWM)	0 - 60 kHz
Potential test voltage phase to phase	2400 Vdc (2 sec.)
Potential test voltage phase to ground	3200 Vdc (2 sec.)
IP Protection	IP20
Saturation current	4 x Rated current (Switch ON) 2 x In 10 seconds 1.5 In for 10 minutes 1.5 x Nominal current
Climatic class	-40 to 85°C
MTBF at 40°C	250,000 Hours

ELECTRICAL CHARACTERISTICS

FIN960F	Rated Current (S1)	Peak Current (S6)	Power Loss (W)
.050.M010	50	75	70
.110.M010	110	150	110
.160.M010	160	200	150
.095.M020	95	130	90
.130.M025	130	160	115
.160.M025	160	180	170
.090.M030	90	120	60
.050.M040	50	75	80
.110.M040	110	150	280
.200.M040	200	240	580
.085.M060	85	120	280
.135.M060	135	165	300
.170.M060	170	205	520
.120.M100	120	145	305
.200.M100	200	240	820

CONNECTIONS

Solid Cable (mm ²)	LINE		PE	
	Stranded Cable (mm ²)	Terminal Block Torque (Nm)	Torque (Nm)	Torque (Nm)
2.5 - 50	2.5 - 35	5	5	5
10 - 70	10 - 50	6	6	6
10 - 95	10 - 50	10	10	10
10 - 70	10 - 50	6	6	6
10 - 95	10 - 70	10	10	10
10 - 95	10 - 70	10	10	10
10 - 70	10 - 50	6	6	6
2.5 - 50	2.5 - 35	5	5	5
10 - 70	10 - 50	6	6	6
16 - 150	16 - 95	20	20	20
10 - 70	10 - 50	6	6	6
10 - 95	10 - 70	10	10	10
10 - 95	10 - 70	10	10	10
10 - 70	10 - 50	6	6	6
16 - 250	16 - 95	20	20	20

Custom nominal current and inductance value combinations are available to accommodate specific motor characteristics and working cycles.

S1 (100%) at 40C° - S6 (40% 2 min) at 40C°

MECHANICAL DIMENSIONS mm

FIN960F	A	B	C	D	E	F	G	Weight Kg.	Case
.050.M010	230	250	80	100	7	270	120	6	1
.110.M010	240	260	110	140	7	270	150	18	2
.160.M010	370	400	170	230	12	350	250	37	3
.095.M020	240	260	110	140	7	270	150	20	2
.160.M025	500	540	200	260	12	500	300	75	5
.130.M030	500	540	200	260	12	500	300	65	5
.050.M040	280	300	140	160	8	280	180	19	6
.110.M040	500	540	200	260	12	500	300	65	5
.200.M040	500	540	200	260	12	500	300	120	5
.085.M060	500	540	200	260	12	500	300	65	5
.135.M060	500	540	200	260	12	500	300	88	5
.170.M060	500	540	200	260	12	500	300	105	5
.120.M100	500	540	200	260	12	500	300	95	5
.200.M100	660	700	320	390	12	600	410	200	7

CASE 1, 2, 6

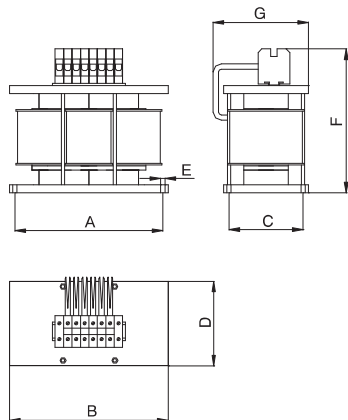

CASE 3, 4, 5, 7

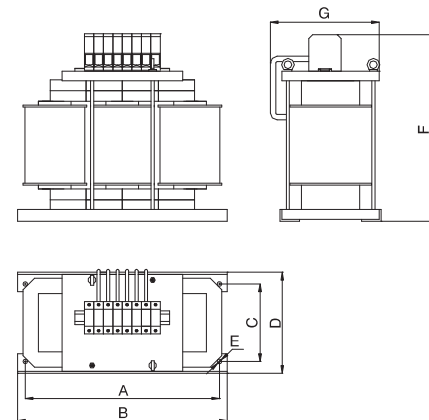



Datasheet 202401

Output filter with excellent attenuation for effective dV/dt reduction

APPROVALS:



FINFVT.(002 - 075).M

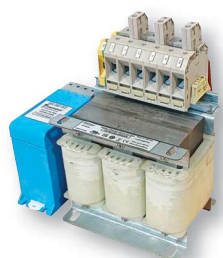

FINFVT.(090 - 180).M

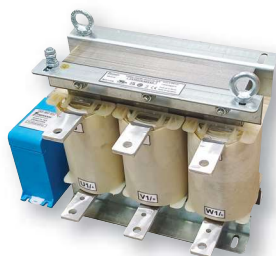

FINFVT.(210 - 260).B



FINFVT.(320 - 1000).B

CHARACTERISTICS

- Rated current from 2 to 1000A
- Compact design
- Enclosure available upon request

MARKETS

- Applications with motor cables up to 250 m
- Variable frequency drives / servo drives
- Industrial automation
- Water treatment plants
- Agriculture

CODE

FVT0012.4MXXA

Model	Current	Voltage	Connection	Protection	Open Frame
FVT 0012	4	M	XX	A	
	4 = 400/480 V	M = Clamp	XX = None	T1 = 1 Thermocouple	
	7 = 690 V	B = Bus bar	T1 = 1 Thermocouple	T3 = 3 Thermocouples	

BENEFITS

- Minimal power loss
- Ventilation-free design
- Eliminates voltage peaks and high frequency noise

ELECTRICAL DIAGRAM

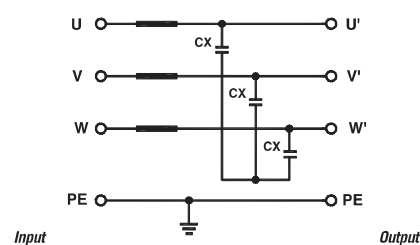

TYPICAL MEASUREMENT

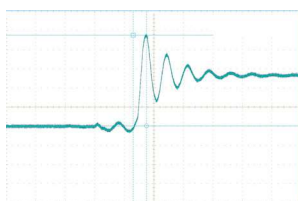

Motor side pulse without FVT filter

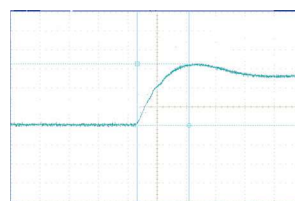

Motor side pulse with FVT filter

TECHNICAL SPECIFICATIONS

Nominal voltage	0 - 480 Vac or 0 - 690 Vac
Frequency	0 - 70 Hz
Rated current	2 - 1000 A
Ambient temperature	40°C
	Derating $I_T = \sqrt{(85-T)/45}$
Altitude	1000m
	Derating 0.5% every 100m
Relative humidity	<95% no condensation
Overload capability	1.5 x Rated current
IP Protection	IP20 up to 180 A IP00 over 260 A
Optional	Current and inductance customizations available on request

ELECTRICAL CHARACTERISTICS

FVT	Voltage (V)	Rated Current 40°C	Power Loss (W)
FVT0002.4MXXA	480	2	7
FVT0004.4MXXA	480	4	9
FVT0006.4MXXA	480	6	12
FVT0008.4MXXA	480	8	15
FVT0012.4MXXA	480	12	22
FVT0016.4MXXA	480	16	28
FVT0020.4MXXA	480	20	31
FVT0025.4MXXA	480	25	32
FVT0032.4MXXA	480	32	39
FVT0038.4MXXA	480	38	51
FVT0045.4MXXA	480	45	55
FVT0060.4MXXA	480	60	61
FVT0075.4MXXA	480	75	68
FVT0090.4MXXA	480	90	77
FVT0110.4MXXA	480	110	100
FVT0130.4MXXA	480	130	93
FVT0150.4MXXA	480	150	104
FVT0180.4MXXA	480	180	116

CONNECTIONS

LINE		PE		CAPACITORS		CAPACITOR BOX	
Cable (mm ²)	Terminal Torque (Nm)	Cable (mm ²)	Terminal Torque (Nm)	Cable (mm ²)	Terminal Torque (Nm)	Cable (mm ²)	Terminal Torque (Nm)
0.5-4	0.8	0.5-4	0.8	0.5-4	0.8	0.5-4	0.8
0.5-4	0.8	0.5-4	0.8	0.5-4	0.8	0.5-4	0.8
0.5-4	0.8	0.5-4	0.8	0.5-4	0.8	0.5-4	0.8
0.5-4	0.8	0.5-4	0.8	0.5-4	0.8	0.5-4	0.8
0.5-4	0.8	0.5-4	0.8	0.5-4	0.8	0.5-4	0.8
0.5-6	1.8	0.5-6	1.8	0.5-6	1.8	0.5-4	0.8
0.5-6	1.8	0.5-6	1.8	0.5-6	1.8	0.5-4	0.8
0.5-10	1.3	0.5-10	1.3	0.5-10	1.3	0.5-4	0.8
0.5-10	1.3	0.5-10	1.3	0.5-10	1.3	0.5-4	0.8
1.5-16	3.4	1.5-16	3.4	1.5-16	3.4	0.5-4	0.8
1.5-16	3.4	1.5-16	3.4	1.5-16	3.4	0.5-4	0.8
1.5-35	6.5	1.5-16	3.4	1.5-35	6.5	0.5-4	0.8
1.5-35	6.5	1.5-16	3.4	1.5-35	6.5	0.5-4	0.8
10-70	6	2.5-50	5	05-6	1.8	0.5-4	0.8
10-70	6	2.5-50	5	05-6	1.8	0.5-4	0.8
10-95	10	10-70	6	05-6	1.8	0.5-4	0.8
16-150	20	10-95	10	05-6	1.8	0.5-4	0.8
16-150	20	10-95	10	05-6	1.8	0.5-4	0.8

ELECTRICAL CHARACTERISTICS

FVT	Voltage (V)	Rated Current 40°C	Power Loss (W)
FVT0210.4BXXA	480	210	122
FVT0260.4BXXA	480	260	151
FVT0320.4BXXA	480	320	134
FVT0380.4BXXA	480	380	150
FVT0440.4BXXA	480	440	165
FVT0500.4BXXA	480	500	191
FVT0600.4BXXA	480	600	234
FVT0700.4BXXA	480	700	280
FVT0800.4BXXA	480	800	0
FVT0900.4BXXA	480	900	0
FVT1000.4BXXA	480	1000	0

CONNECTIONS

LINE	PE	CAPACITORS	CAPACITOR BOX	
Torque (Nm)	Screw (mm)	Torque (Nm)	Cable (mm ²)	Terminal Torque (Nm)
25	8x25	14	0.5-4	0.8
50	8x25	14	0.5-4	0.8
50	8x25	14	0.5-4	0.8
50	8x25	14	0.5-4	0.8
50	8x25	14	0.5-4	0.8
50	8x25	14	0.5-4	0.8
50	8x25	14	0.5-4	0.8
50	10x35	14	0.5-4	0.8
50	10x35	14	0.5-4	0.8
50	10x35	14	0.5-4	0.8
50	10x35	14	0.5-4	0.8

MECHANICAL DIMENSIONS mm

FVT	A	B	C	D	E	F	G	H	P	Q	R	S	T	U	Weight Kg.	Case
FVT0002.4MXXA	150	98	185	125	56	6	13	73	170	59	130	35	153	4.5	3.5	1
FVT0004.4MXXA	150	98	185	125	56	6	13	73	170	59	130	35	153	4.5	3.6	1
FVT0006.4MXXA	150	98	185	125	56	6	13	73	170	59	130	35	153	4.5	3.7	1
FVT0008.4MXXA	150	98	185	125	56	6	13	73	170	59	130	35	153	4.5	3.8	1
FVT0012.4MXXA	150	98	185	125	56	6	13	73	170	59	130	35	153	4.5	3.9	1
FVT0016.4MXXA	150	98	189	125	56	6	13	73	170	59	130	35	153	4.5	4.1	1
FVT0020.4MXXA	150	103	189	125	61	6	13	78	170	59	130	35	153	4.5	4.7	1
FVT0025.4MXXA	150	118	193	125	71	6	13	88	170	59	130	35	153	4.5	5.8	1
FVT0032.4MXXA	150	118	193	125	71	6	13	88	170	59	130	35	153	4.5	6.1	1
FVT0038.4MXXA	180	130	231	150	72	8	20	100	170	59	130	35	153	4.5	7.3	1
FVT0045.4MXXA	180	140	231	150	82	8	20	110	170	59	130	35	153	4.5	8.6	1
FVT0060.4MXXA	180	150	231	150	92	8	20	120	170	59	130	35	153	4.5	10.2	1
FVT0075.4MXXA	180	150	231	150	92	8	20	120	170	59	130	35	153	4.5	10.6	1
FVT0090.4MXXA	180	175	264	150	107	8	20	135	170	59	130	35	153	4.5	12.9	2
FVT0110.4MXXA	240	170	330	200	87	8	20	119	170	59	130	35	153	4.5	15.7	2
FVT0130.4MXXA	240	180	334	200	97	8	20	129	170	59	130	35	153	4.5	18.5	2
FVT0150.4MXXA	240	210	334	200	117	8	20	149	170	59	130	35	153	4.5	23.9	2
FVT0180.4MXXA	240	210	334	200	117	8	20	149	170	59	130	35	153	4.5	24.5	2

CASE 1

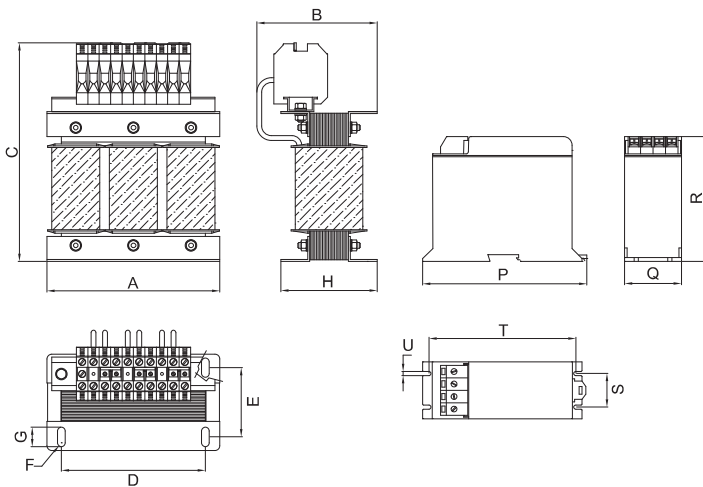

CASE 2

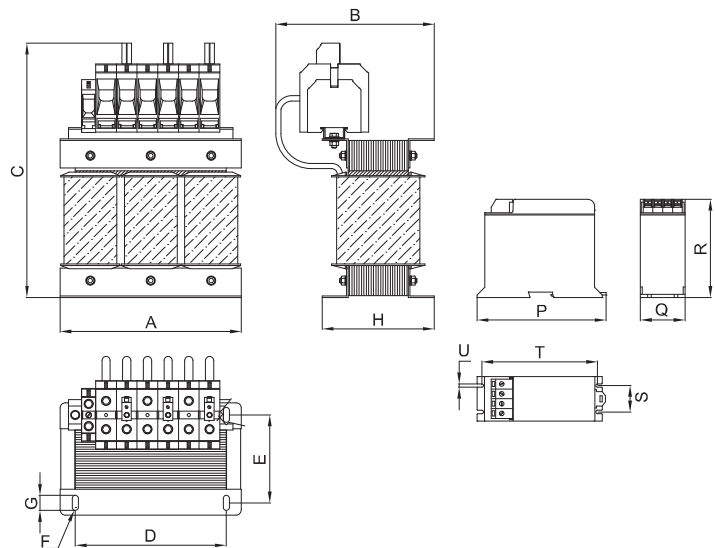

MECHANICAL DIMENSIONS mm

FVT	A	B	C	D	E	F	G	H	I	M	O	J	K	X	Y	P	Q	R	S	T	U	Weight Kg.	Case
FVT0210.4BXXA	300	206	295	260	103	8	26	143	11		7		15	30	6	170	59	130	35	153	4.5	28.8	3
FVT0260.4BXXA	300	210	295	260	103	8	26	143	13		7		20	40	6	170	59	130	35	153	4.5	29.4	3
FVT0320.4BXXA	300	247	295	260	113	8	26	153	13	20	7	20	15	50	6	170	59	130	35	153	4.5	35.3	4
FVT0380.4BXXA	300	256	295	260	113	8	26	153	13	14	7	20	15	40	10	170	59	130	35	153	4.5	37.0	4
FVT0440.4BXXA	360	247	345	260	115	8	26	155	13	14	7	20	15	50	10	170	59	130	35	153	4.5	50.1	4
FVT0500.4BXXA	360	247	345	260	115	8	26	155	13	20	7	20	15	50	10	170	59	130	35	153	4.5	50.2	4
FVT0600.4BXXA	360	277	345	260	145	8	26	185	13	20	7	20	15	50	10	170	59	130	35	153	4.5	69.0	4
FVT0700.4BXXA	480	316	445	360	154	10	30	200	13	20	7	20	20	60	10	170	59	130	35	153	4.5	97.2	4
FVT0800.4BXXA	480	357	459	360	184	10	30	230	13	40	7	40	20	80	10	170	59	130	35	153	4.5	126	5
FVT0900.4BXXA	480	372	459	360	214	10	30	260	13	40	7	40	20	80	10	170	59	130	35	153	4.5	156	5
FVT1000.4BXXA	480	372	459	360	214	10	30	260	13	40	7	40	20	80	10	170	59	130	35	153	4.5	156	5

CASE 3

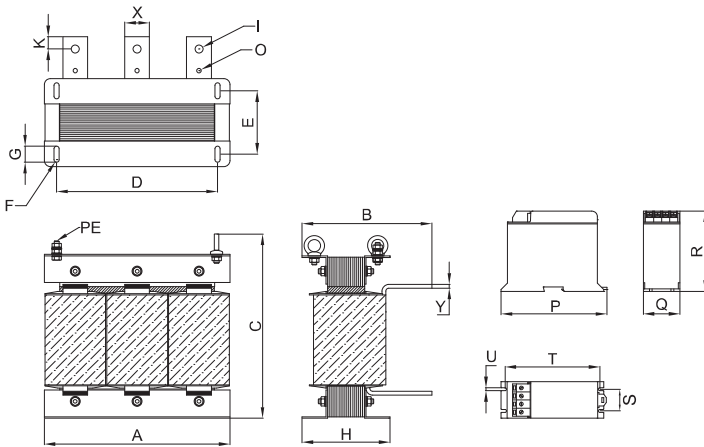

CASE 4.5

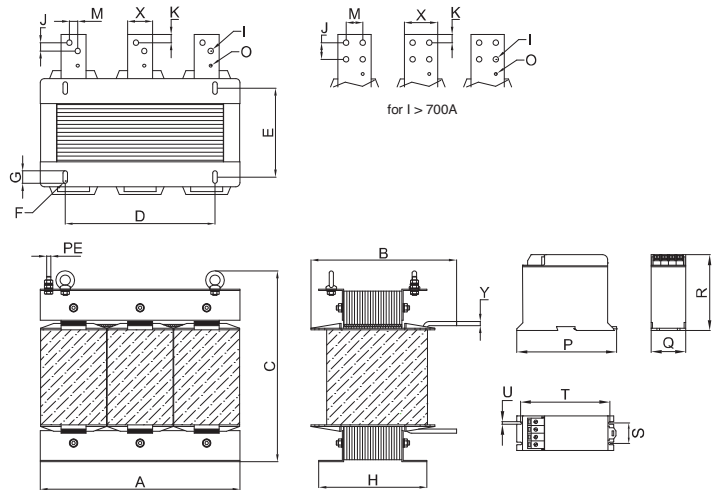

ELECTRICAL CHARACTERISTICS

FVT	Voltage (V)	Rated Current 40°C	Power Loss (W)
FVT0002.7MXXA	690	2	9
FVT0004.7MXXA	690	4	15
FVT0006.7MXXA	690	6	21
FVT0008.7MXXA	690	8	25
FVT0012.7MXXA	690	12	34
FVT0016.7MXXA	690	16	36
FVT0020.7MXXA	690	20	53
FVT0025.7MXXA	690	25	48
FVT0032.7MXXA	690	32	60
FVT0038.7MXXA	690	38	55
FVT0045.7MXXA	690	45	69
FVT0060.7MXXA	690	60	88
FVT0075.7MXXA	690	75	103
FVT0090.7MXXA	690	90	110
FVT0110.7MXXA	690	110	131
FVT0130.7MXXA	690	130	151
FVT0150.7MXXA	690	150	156
FVT0180.7MXXA	690	180	175

CONNECTIONS

LINE		PE		CAPACITORS		CAPACITOR BOX	
Cable (mm ²)	Terminal Torque (Nm)	Cable (mm ²)	Terminal Torque (Nm)	Cable (mm ²)	Terminal Torque (Nm)	Cable (mm ²)	Terminal Torque (Nm)
0.5-4	0.8	0.5-4	0.8	0.5-4	0.8	0.5-4	0.8
0.5-4	0.8	0.5-4	0.8	0.5-4	0.8	0.5-4	0.8
0.5-4	0.8	0.5-4	0.8	0.5-4	0.8	0.5-4	0.8
0.5-4	0.8	0.5-4	0.8	0.5-4	0.8	0.5-4	0.8
0.5-4	0.8	0.5-4	0.8	0.5-4	0.8	0.5-4	0.8
0.5-6	1.8	0.5-6	1.8	0.5-6	1.8	0.5-4	0.8
0.5-6	1.8	0.5-6	1.8	0.5-6	1.8	0.5-4	0.8
0.5-10	1.3	0.5-10	1.3	0.5-10	1.3	0.5-4	0.8
0.5-10	1.3	0.5-10	1.3	0.5-10	1.3	0.5-4	0.8
1.5-16	3.4	1.5-16	3.4	1.5-16	3.4	0.5-4	0.8
1.5-16	3.4	1.5-16	3.4	1.5-16	3.4	0.5-4	0.8
1.5-35	6.5	1.5-16	3.4	1.5-35	6.5	0.5-4	0.8
1.5-35	6.5	1.5-16	3.4	1.5-35	6.5	0.5-4	0.8
10-70	6	2.5-50	5	05-6	1.8	0.5-4	0.8
10-70	6	2.5-50	5	05-6	1.8	0.5-4	0.8
10-95	10	10-70	6	05-6	1.8	0.5-4	0.8
16-150	20	10-95	10	05-6	1.8	0.5-4	0.8
16-150	20	10-95	10	05-6	1.8	0.5-4	0.8

ELECTRICAL CHARACTERISTICS

FVT	Voltage (V)	Rated Current 40°C	Power Loss (W)
FVT0210.7BXXA	690	210	1158
FVT0260.7BXXA	690	260	183
FVT0320.7BXXA	690	320	208
FVT0380.7BXXA	690	380	220
FVT0440.7BXXA	690	440	268
FVT0500.7BXXA	690	500	284
FVT0600.7BXXA	690	600	343
FVT0700.7BXXA	690	700	401
FVT0800.7BXXA	690	800	578
FVT0900.7BXXA	690	900	640
FVT1000.7BXXA	690	1000	654

CONNECTIONS

LINE	PE	CAPACITORS	CAPACITOR BOX	
Torque (Nm)	Screw (mm)	Torque (Nm)	Cable (mm ²)	Terminal Torque (Nm)
25	8x25	14	0.5-4	0.8
50	8x25	14	0.5-4	0.8
50	8x25	14	0.5-4	0.8
50	8x25	14	0.5-4	0.8
50	8x25	14	0.5-4	0.8
50	8x25	14	0.5-4	0.8
50	8x25	14	0.5-4	0.8
50	10x35	14	0.5-4	0.8
50	10x35	14	0.5-4	0.8
50	10x35	14	0.5-4	0.8
50	10x35	14	0.5-4	0.8

MECHANICAL DIMENSIONS mm

FVT	A	B	C	D	E	F	G	H	P	Q	R	S	T	U	Weight Kg.	Case
FVT0002.7MXXA	150	98	185	125	56	6	13	73	170	59	130	35	153	4.5	2.6	1
FVT0004.7MXXA	150	98	185	125	56	6	13	73	170	59	130	35	153	4.5	2.7	1
FVT0006.7MXXA	150	98	185	125	56	6	13	73	170	59	130	35	153	4.5	2.9	1
FVT0008.7MXXA	150	98	185	125	56	6	13	73	170	59	130	35	153	4.5	3.1	1
FVT0012.7MXXA	150	103	185	125	61	6	13	78	170	59	130	35	153	4.5	3.8	1
FVT0016.7MXXA	150	113	189	125	71	8	13	88	170	59	130	35	153	4.5	5.1	1
FVT0020.7MXXA	180	125	214	150	72	8	20	100	170	59	130	35	153	4.5	6.3	1
FVT0025.7MXXA	180	140	218	150	82	8	20	110	170	59	130	35	153	4.5	7	1
FVT0032.7MXXA	180	140	218	150	82	8	20	110	170	59	130	35	153	4.5	8.2	1
FVT0038.7MXXA	180	150	231	150	92	8	20	120	170	59	130	35	153	4.5	9.9	1
FVT0045.7MXXA	180	165	231	150	107	8	20	135	170	59	130	35	153	4.5	11.9	1
FVT0060.7MXXA	240	149	281	200	87	8	20	119	170	59	130	35	153	4.5	15	1
FVT0075.7MXXA	240	159	281	200	97	8	20	129	170	59	130	35	153	4.5	17.9	1
FVT0090.7MXXA	240	169	316	200	97	8	20	129	170	59	130	35	153	4.5	18.8	2
FVT0110.7MXXA	240	189	316	200	117	8	20	149	170	59	130	35	153	4.5	24.3	2
FVT0130.7MXXA	300	200	384	260	103	8	26	143	170	59	130	35	153	4.5	28.5	2
FVT0150.7MXXA	300	200	384	260	103	8	26	143	170	59	130	35	153	4.5	29.6	2
FVT0180.7MXXA	300	217	384	260	113	8	26	153	170	59	130	35	153	4.5	34.1	2

CASE 1

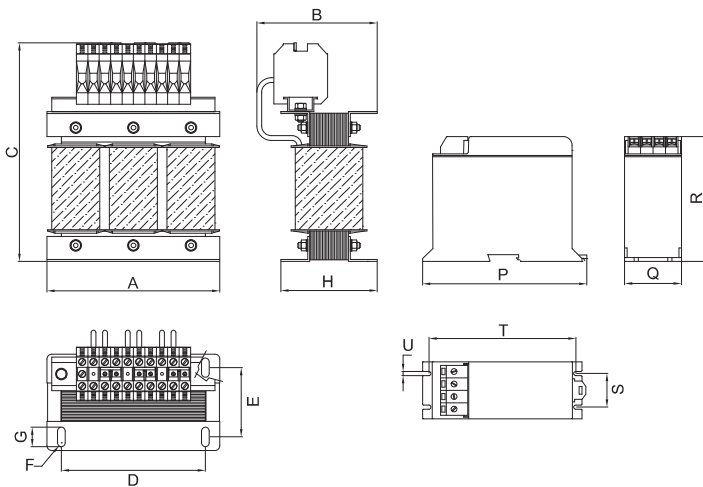

CASE 2

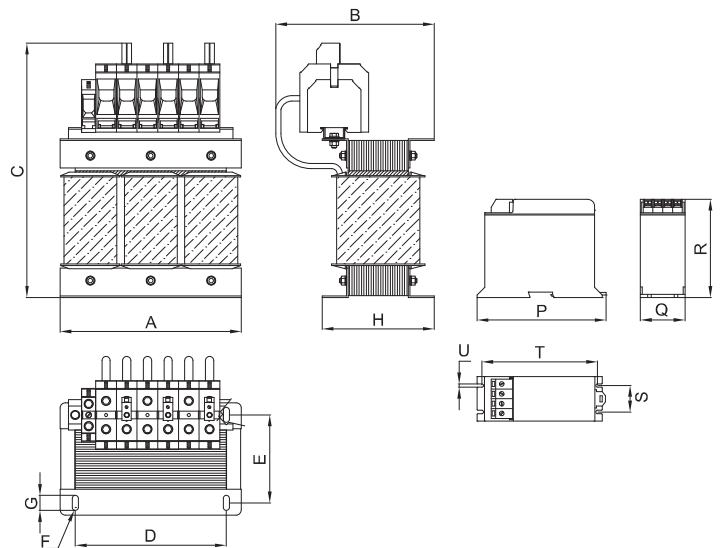

MECHANICAL DIMENSIONS mm

FVT	A	B	C	D	E	F	G	H	I	M	O	J	K	X	Y	P	Q	R	S	T	U	Weight Kg.	Case
FVT0210.7BXXA	300	292	295	260	133	8	26	173	11		7		15	30	6	170	59	130	35	153	4.5	45	3
FVT0260.7BXXA	360	292	345	260	115	8	26	155	13	20	7	20	15	50	6	170	59	130	35	153	4.5	51	3
FVT0320.7BXXA	360	303	345	260	115	8	26	155	13	20	7	20	15	50	6	170	59	130	35	153	4.5	54.9	4
FVT0380.7BXXA	360	303	345	260	145	8	26	185	13	20	7	20	15	50	6	170	59	130	35	153	4.5	72.6	4
FVT0440.7BXXA	360	332	345	260	165	8	26	205	13	14	7	20	15	40	10	170	59	130	35	153	4.5	83.3	4
FVT0500.7BXXA	360	335	345	260	165	8	26	205	13	20	7	20	15	50	10	170	59	130	35	153	4.5	86	4
FVT0600.7BXXA	480	316	459	360	154	10	30	200	13	20	7	20	15	50	10	170	59	130	35	153	4.5	106.3	4
FVT0700.7BXXA	480	343	459	360	184	10	30	230	13	20	7	20	20	60	10	170	59	130	35	153	4.5	133.5	4
FVT0800.7BXXA	600	400	559	380	210	14	30	254	13	40	7	40	20	80	10	170	59	130	35	153	4.5	235	5
FVT0900.7BXXA	600	400	559	380	210	14	30	254	13	40	7	40	20	80	10	170	59	130	35	153	4.5	235	5
FVT1000.7BXXA	600	424	559	380	210	14	30	254	13	40	7	40	20	100	10	170	59	130	35	153	4.5	238	5

CASE 3

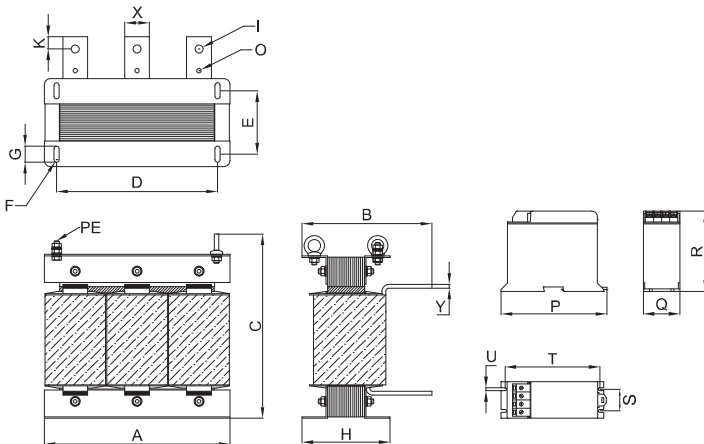

CASE 4.5

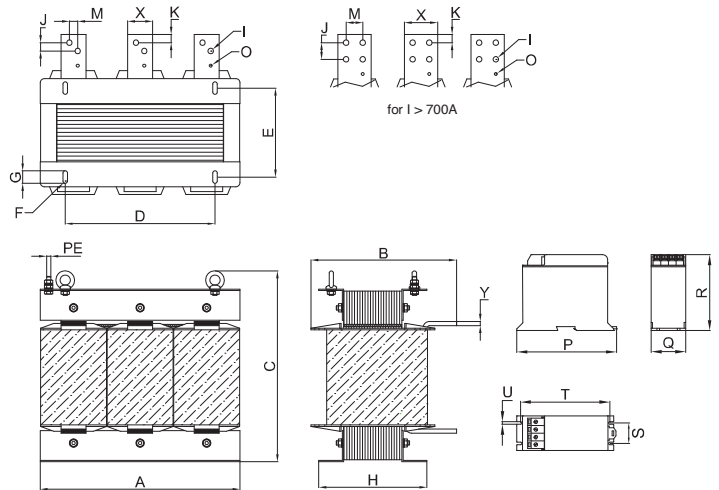



Datasheet 202404

Sine wave filter with excellent attenuation for VFD applications

APPROVALS:



SWF.(002 - 020).M



SWF.(025 - 180).M



SWF.(210 - 380).M



SWF.(440 - 1000).M

CHARACTERISTICS

- Rated current from 2 to 1000A
- Compact design
- Enclosure available upon request

BENEFITS

- Minimal power loss
- Ventilation-free design
- Eliminates high-frequency disturbance

MARKETS

- Applications with motor cables longer than 250m
- Variable frequency drives / servo drives
- Industrial automation
- Water treatment plants
- Agriculture

CODE

SWF0012.4MXXA2

SWF	0012	4	M	XX	A	2
Model	Current	Voltage	Connection	Protection	Open Frame	Min. PWM Freq.
	4 = 400/480 V	7 = 690 V	M = Terminal block B = Bus bar	XX = None T1 = 1 Thermocouple T3 = 3 Thermocouples		2 = 2 kHz 4 = 4 kHz

ELECTRICAL DIAGRAM

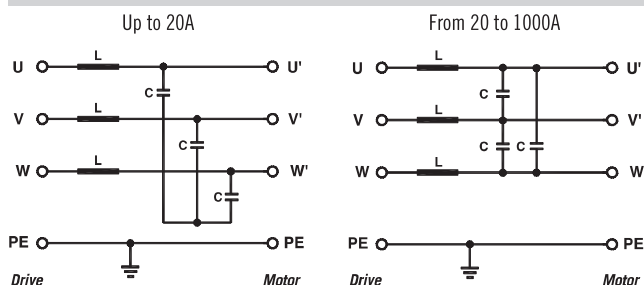

TYPICAL MEASUREMENT

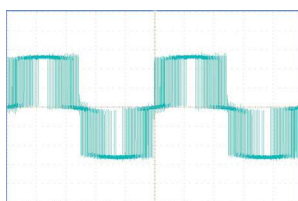

Motor side pulse without SWF filter

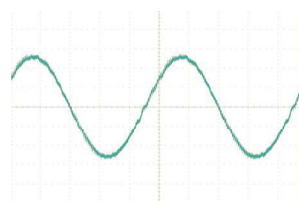

Motor side pulse with SWF filter

TECHNICAL SPECIFICATIONS

Nominal voltage	0 - 480 Vac (690 Vac option)
Frequency	0 - 70 Hz
Rated current	2 to 1000 A
Ambient temperature	40°C
	Derating $I_T = \sqrt{(85-T)/45}$
Altitude	1000 m
	Derating 0.5% every 100 m
Relative humidity	<95% no condensation
Overload capability	1.5 x Rated current
IP Protection	IP20 up to 180 A IP00 over 260 A
Optional	Current and frequency customizations available on request

ELECTRICAL CHARACTERISTICS

SWF	Rated Current 40°C	Min Switching Frequency (kHz)	Power Loss (W)
SWF0002.4MXXA4	2	4	22
SWF0004.4MXXA4	4	4	36
SWF0006.4MXXA4	6	4	50
SWF0008.4MXXA4	8	4	52
SWF0012.4MXXA4	12	4	70
SWF0016.4MXXA4	16	4	73
SWF0020.4MXXA4	20	4	94
SWF0025.4MXXA4	25	4	145
SWF0032.4MXXA4	32	4	164
SWF0038.4MXXA4	38	4	156
SWF0045.4MXXA4	45	4	167
SWF0060.4MXXA4	60	4	191
SWF0075.4MXXA4	75	4	232
SWF0090.4MXXA4	90	4	265
SWF0110.4MXXA4	110	4	268
SWF0130.4MXXA4	130	4	288
SWF0150.4MXXA4	150	4	354
SWF0180.4MXXA4	180	4	327

CONNECTIONS

LINE		PE		CAPACITORS		CAPACITOR BOX	
Cable (mm ²)	Terminal Torque (Nm)	Cable (mm ²)	Terminal Torque (Nm)	Cable (mm ²)	Terminal Torque (Nm)	Cable (mm ²)	Terminal Torque (Nm)
0.5-4	0.8	0.5-4	0.8	0.5-4	0.8	0.5-4	0.8
0.5-4	0.8	0.5-4	0.8	0.5-4	0.8	0.5-4	0.8
0.5-4	0.8	0.5-4	0.8	0.5-4	0.8	0.5-4	0.8
0.5-4	0.8	0.5-4	0.8	0.5-4	0.8	0.5-4	0.8
0.5-4	0.8	0.5-4	0.8	0.5-4	0.8	0.5-4	0.8
0.5-6	1.8	0.5-6	1.8	0.5-6	1.8	0.5-4	0.8
0.5-6	1.8	0.5-6	1.8	0.5-6	1.8	0.5-4	0.8
0.5-10	1.3	0.5-10	1.3	0.5-10	1.3	4-25	2
0.5-10	1.3	0.5-10	1.3	0.5-10	1.3	4-25	2
1.5-16	3.4	1.5-16	3.4	1.5-16	3.4	4-25	2
1.5-16	3.4	1.5-16	3.4	1.5-16	3.4	4-25	2
1.5-35	6.5	1.5-16	3.4	1.5-35	6.5	4-25	2
1.5-35	6.5	1.5-16	3.4	1.5-35	6.5	4-25	2
16-50	5.6	1.5-35	6.5	16-50	5.6	4-25	2
16-50	5.6	1.5-35	6.5	16-50	5.6	4-25	2
35-95	10	16-50	5.6	35-95	10	4-25	2
35-95	10	16-50	5.6	35-95	10	4-25	2
35-95	10	16-50	5.6	35-95	10	4-25	2

ELECTRICAL CHARACTERISTICS

SWF	Rated Current 40°C	Min Switching Frequency (kHz)	Power Loss (W)
SWF0210.4BXXA4	210	4	375
SWF0260.4BXXA4	260	4	467
SWF0320.4BXXA4	320	4	541
SWF0380.4BXXA4	380	4	569
SWF0440.4BXXA4	440	4	634
SWF0500.4BXXA4	500	4	735
SWF0600.4BXXA4	600	4	824
SWF0700.4BXXA4	700	4	869
SWF0800.4BXXA4	800	4	975
SWF0900.4BXXA4	900	4	1050
SWF1000.4BXXA4	1000	4	1305

CONNECTIONS

LINE	PE	CAPACITORS	CAPACITOR BOX	
Torque (Nm)	Screw (mm)	Torque (Nm)	Cable (mm ²)	Terminal Torque (Nm)
25	8x25	14	4-25	2
50	8x25	14	4-25	2
50	8x25	14	4-25	2
50	8x25	14	4-25	2
50	8x25	14	35-95	15
50	8x25	14	35-95	15
50	8x25	14	35-95	15
50	10x35	14	35-95	15
50	10x35	14	-	14
50	10x35	14	-	14
50	10x35	14	-	14

MECHANICAL DIMENSIONS mm

SWF	A	B	C	D	E	F	G	H	P	Q	R	S	T	U	V	Weight Kg.	Cus.
SWF0002.4MXXA4	150	98	185	125	56	6	13	73	170	59	130	35	153	4.5	-	3.5	1
SWF0004.4MXXA4	150	98	185	125	56	6	13	73	170	59	130	35	153	4.5	-	3.5	1
SWF0006.4MXXA4	150	113	185	125	71	6	13	88	170	59	130	35	153	4.5	-	6	1
SWF0008.4MXXA4	180	125	210	150	72	8	20	100	170	59	130	35	153	4.5	-	6	1
SWF0012.4MXXA4	180	125	210	150	72	8	20	100	170	59	130	35	153	4.5	-	8	1
SWF0016.4MXXA4	180	135	214	150	82	8	20	110	170	59	130	35	153	4.5	-	11	1
SWF0020.4MXXA4	180	160	214	150	107	8	20	135	170	59	130	35	153	4.5	-	14	1
SWF0025.4MXXA4	240	159	268	200	97	8	20	129	110	150	232	80	130	6.5	M6x25	18	2
SWF0032.4MXXA4	240	179	268	200	117	8	20	149	110	150	232	80	130	6.5	M6x25	24	2
SWF0038.4MXXA4	240	179	281	200	117	8	20	149	110	150	270	80	130	6.5	M6x25	25	2
SWF0045.4MXXA4	300	173	331	260	103	8	26	143	110	150	270	80	130	6.5	M6x25	19	2
SWF0060.4MXXA4	300	173	331	260	103	8	26	143	110	150	270	80	130	6.5	M6x25	20	2
SWF0075.4MXXA4	360	185	381	260	115	8	26	155	110	150	270	80	130	6.5	M6x25	34	2
SWF0090.4MXXA4	360	195	414	260	115	8	26	155	110	150	270	80	130	6.5	M6x25	37	2
SWF0110.4MXXA4	360	225	414	260	145	8	26	185	110	150	345	80	130	6.5	M6x25	47	2
SWF0130.4MXXA4	360	230	434	260	145	8	26	185	110	150	345	80	130	6.5	M6x25	51	2
SWF0150.4MXXA4	360	250	434	260	165	8	26	205	110	150	345	80	130	6.5	M6x25	82	2
SWF0180.4MXXA4	360	250	434	260	165	8	26	205	150	190	311	100	170	6.5	M6x25	83	2

CASE 1

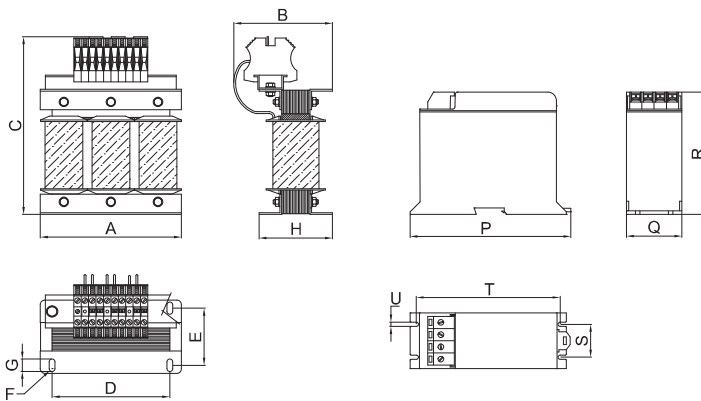

CASE 2

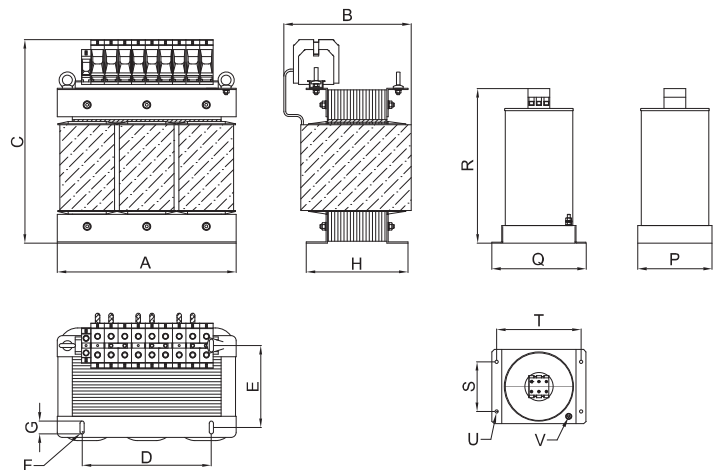

MECHANICAL DIMENSIONS mm

SWF	A	B	C	D	E	F	G	H	I	M	O	J	K	X	Y	P	Q	R	S	T	U	V	W	X1	Y1	Weight Kg.	Cus.
SWF0210.4BXXA4	360	343	345	260	185	8	26	225	11	-	9	-	20	40	6	150	190	326	100	170	6.5	M6x25	-	-	-	93	3
SWF0260.4BXXA4	480	395	459	360	184	10	30	230	13	-	11	-	20	40	6	150	190	326	100	170	6.5	M6x25	-	-	-	128	3
SWF0320.4BXXA4	480	398	459	360	214	10	30	260	13	20	11	20	15	50	6	150	190	311	100	170	6.5	M6x25	-	-	-	167	4
SWF0380.4BXXA4	480	395	459	360	214	10	30	260	13	20	11	20	15	50	6	150	190	326	100	170	6.5	M6x25	-	-	-	170	4
SWF0440.4BXXA4	480	450	459	360	234	10	30	280	13	14	11	20	15	40	10	432	210	400	195	160	5	M5x20	-	-	-	202	5
SWF0500.4BXXA4	600	398	559	380	210	14	30	254	13	20	11	20	15	50	10	432	210	400	195	160	5	M5x20	-	-	-	247	5
SWF0600.4BXXA4	600	434	559	380	240	14	30	284	13	20	11	20	15	60	10	432	210	400	195	160	5	M5x20	-	-	-	298	5
SWF0700.4BXXA4	600	434	559	380	240	14	30	284	13	20	11	20	20	60	10	432	210	400	195	160	5	M5x20	-	-	-	305	5
SWF0800.4BXXA4	600	464	559	380	240	14	30	284	13	40	11	40	20	80	10	450	338	422	150	410	9	M8x20	29	20	6	301	6
SWF0900.4BXXA4	600	481	559	380	260	14	30	304	13	40	11	40	20	80	10	450	338	422	150	410	9	M8x20	29	20	6	332	6
SWF1000.4BXXA4	600	531	559	380	300	14	30	344	13	40	11	40	20	100	10	450	338	422	150	410	9	M8x20	29	20	6	400	6

CASE 3

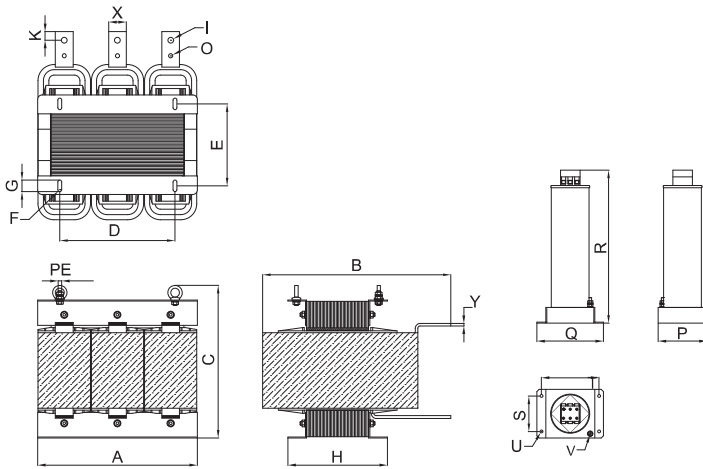

CASE 4

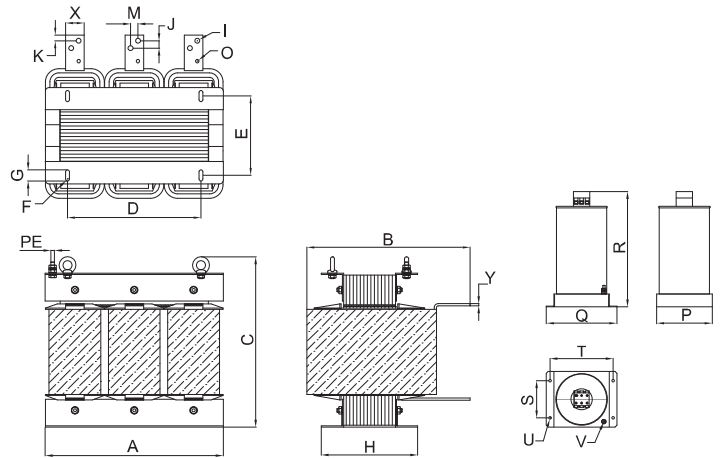

CASE 5

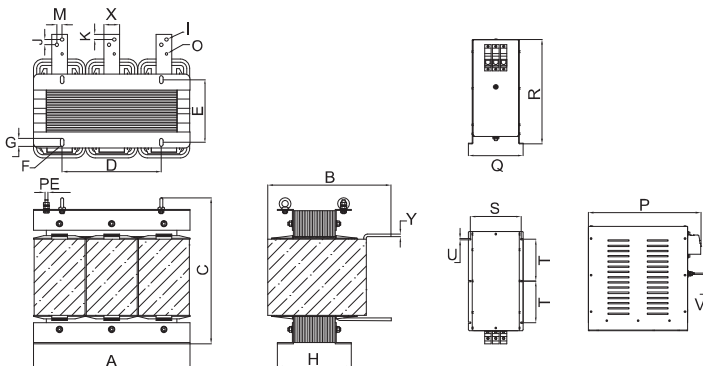

CASE 6

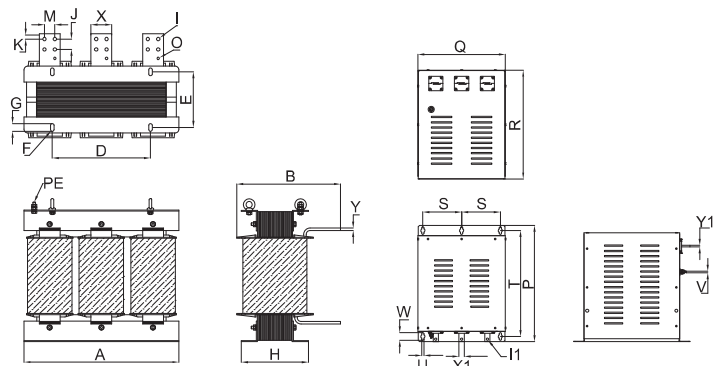

ELECTRICAL CHARACTERISTICS

SWF	Rated Current 40°C	Min Switching Frequency (kHz)	Power Loss (W)
SWF0002.4MXXA2	2	2	20
SWF0004.4MXXA2	4	2	135
SWF0006.4MXXA2	6	2	138
SWF0008.4MXXA2	8	2	163
SWF0012.4MXXA2	12	2	167
SWF0016.4MXXA2	16	2	210
SWF0020.4MXXA2	20	2	229
SWF0025.4MXXA2	25	2	278
SWF0032.4MXXA2	32	2	329
SWF0038.4MXXA2	38	2	313
SWF0045.4MXXA2	45	2	350
SWF0060.4MXXA2	60	2	374
SWF0075.4MXXA2	75	2	556
SWF0090.4MXXA2	90	2	630
SWF0110.4MXXA2	110	2	821
SWF0130.4MXXA2	130	2	834
SWF0150.4MXXA2	150	2	970
SWF0180.4MXXA2	180	2	1033

CONNECTIONS

LINE		PE		CAPACITORS		CAPACITOR BOX	
Cable (mm ²)	Terminal Torque (Nm)	Cable (mm ²)	Terminal Torque (Nm)	Cable (mm ²)	Terminal Torque (Nm)	Cable (mm ²)	Terminal Torque (Nm)
0.5-4	0.8	0.5-4	0.8	0.5-4	0.8	0.5-4	0.8
0.5-4	0.8	0.5-4	0.8	0.5-4	0.8	0.5-4	0.8
0.5-4	0.8	0.5-4	0.8	0.5-4	0.8	0.5-4	0.8
0.5-4	0.8	0.5-4	0.8	0.5-4	0.8	0.5-4	0.8
0.5-4	0.8	0.5-4	0.8	0.5-4	0.8	0.5-4	0.8
0.5-6	1.8	0.5-6	1.8	0.5-6	1.8	0.5-4	0.8
0.5-6	1.8	0.5-6	1.8	0.5-6	1.8	0.5-4	0.8
0.5-10	1.3	0.5-10	1.3	0.5-10	1.3	4-25	2
0.5-10	1.3	0.5-10	1.3	0.5-10	1.3	4-25	2
1.5-16	3.4	1.5-16	3.4	1.5-16	3.4	4-25	2
1.5-16	3.4	1.5-16	3.4	1.5-16	3.4	4-25	2
1.5-35	6.5	1.5-16	3.4	1.5-35	6.5	4-25	2
1.5-35	6.5	1.5-16	3.4	1.5-35	6.5	4-25	2
16-50	5.6	1.5-35	6.5	16-50	5.6	4-25	2
16-50	5.6	1.5-35	6.5	16-50	5.6	4-25	2
35-95	10	16-50	5.6	35-95	10	4-25	2
35-95	10	16-50	5.6	35-95	10	4-25	2
35-95	10	16-50	5.6	35-95	10	4-25	2

ELECTRICAL CHARACTERISTICS

SWF	Rated Current 40°C	Min Switching Frequency (kHz)	Power Loss (W)
SWF0210.4BXXA2	210	2	1104
SWF0260.4BXXA2	260	2	467
SWF0320.4BXXA2	320	2	541
SWF0380.4BXXA2	380	2	569
SWF0440.4BXXA2	440	2	634
SWF0500.4BXXA2	500	2	735
SWF0600.4BXXA2	600	2	824
SWF0700.4BXXA2	700	2	1353
SWF0800.4BXXA2	800	2	1497
SWF0900.4BXXA2	900	2	1413
SWF1000.4BXXA2	1000	2	1388

CONNECTIONS

LINE	PE	CAPACITORS	CAPACITOR BOX	
Torque (Nm)	Screw (mm)	Torque (Nm)	Cable (mm ²)	Terminal Torque (Nm)
25	8x25	14	4-25	2
50	8x25	14	4-25	2
50	8x25	14	4-25	2
50	8x25	14	4-25	2
50	8x25	14	35-95	15
50	8x25	14	35-95	15
50	8x25	14	35-95	15
50	10x35	14	35-95	15
50	10x35	14	-	14
50	10x35	14	-	14
50	10x35	14	-	14

MECHANICAL DIMENSIONS mm

SWF	A	B	C	D	E	F	G	H	P	Q	R	S	T	U	V	Weight Kg.	Case
SWF0002.4MXXA2	150	88	185	125	56	6	13	73	170	59	130	35	153	4.5	-	5	1
SWF0004.4MXXA2	150	103	185	125	71	6	13	88	170	59	130	35	153	4.5	-	7	1
SWF0006.4MXXA2	180	115	200	150	72	8	20	100	170	59	130	35	153	4.5	-	10	1
SWF0008.4MXXA2	180	125	200	150	82	8	20	110	170	59	130	35	153	4.5	-	11	1
SWF0012.4MXXA2	180	135	200	150	92	8	20	120	170	59	130	35	153	4.5	-	14	1
SWF0016.4MXXA2	180	150	214	150	107	8	20	135	170	59	130	35	153	4.5	-	16	1
SWF0020.4MXXA2	240	144	264	200	97	8	20	130	170	59	130	35	153	4.5	-	17	1
SWF0025.4MXXA2	240	164	268	200	117	8	20	150	110	150	232	80	130	6.5	M6x25	24	2
SWF0032.4MXXA2	240	164	268	200	117	8	20	150	110	150	232	80	130	6.5	M6x25	25	2
SWF0038.4MXXA2	300	158	331	260	103	8	26	142	110	150	270	80	130	6.5	M6x25	29	2
SWF0045.4MXXA2	300	158	331	260	103	8	26	142	110	150	270	80	130	6.5	M6x25	30	2
SWF0060.4MXXA2	300	188	331	260	133	8	26	172	110	150	270	80	130	6.5	M6x25	46	2
SWF0075.4MXXA2	300	198	331	260	143	8	26	182	110	150	270	80	130	6.5	M6x25	47	2
SWF0090.4MXXA2	360	250	389	260	115	8	26	154	110	150	270	80	130	6.5	M6x25	53	2
SWF0110.4MXXA2	360	225	389	260	165	8	26	204	110	150	345	80	130	6.5	M6x25	82	2
SWF0130.4MXXA2	360	230	434	260	185	8	26	224	110	150	345	80	130	6.5	M6x25	98	2
SWF0150.4MXXA2	360	395	340	260	185	8	26	224	110	150	345	80	130	6.5	M6x25	97	2
SWF0180.4MXXA2	480	460	450	360	154	10	30	200	150	190	311	100	170	6.5	M6x25	103	2

CASE 1

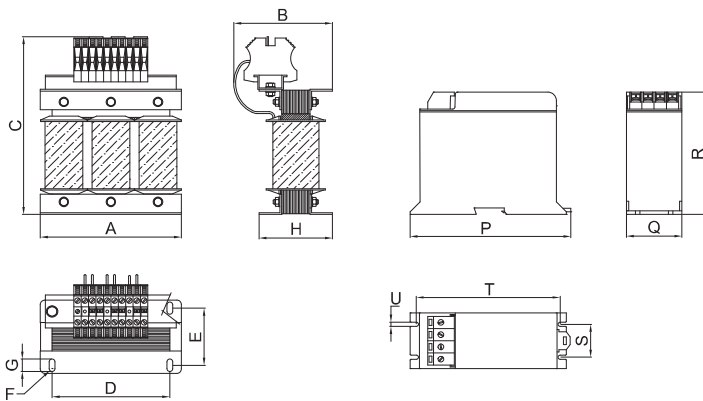

CASE 2

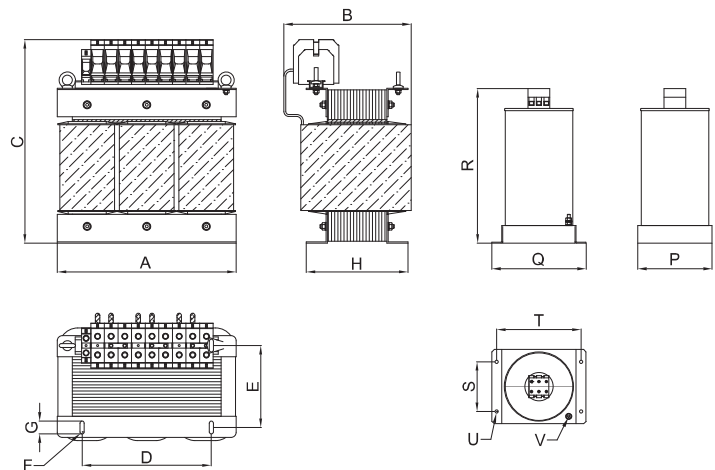

MECHANICAL DIMENSIONS mm

SWF	A	B	C	D	E	F	G	H	I	M	O	J	K	X	Y	P	Q	R	S	T	U	V	W	X1	Y1	Weight Kg.	Case
SWF0210.4BXXA2	480	351	450	360	184	10	30	230	11	-	9	-	15	30	6	150	190	326	100	170	6.5	M6x25	-	-	-	136	3
SWF0260.4BXXA2	480	440	450	360	214	10	30	260	13	-	11	-	15	40	6	150	190	326	100	170	6.5	M6x25	-	-	-	178	3
SWF0320.4BXXA2	600	459	559	380	210	14	30	254	13	20	11	20	15	50	10	150	190	311	100	170	6.5	M6x25	-	-	-	256	4
SWF0380.4BXXA2	600	493	559	380	210	14	30	254	13	20	11	20	15	50	10	150	190	326	100	170	6.5	M6x25	-	-	-	271	4
SWF0440.4BXXA2	600	493	559	380	210	14	30	254	13	20	11	20	15	50	10	432	210	400	195	160	5	M5x20	-	-	-	273	5
SWF0500.4BXXA2	600	502	559	380	240	14	30	284	13	20	11	20	15	50	10	432	210	400	195	160	5	M5x20	-	-	-	325	5
SWF0600.4BXXA2	600	491	559	380	240	14	30	284	13	20	11	20	20	60	10	432	210	400	195	160	5	M5x20	-	-	-	335	5
SWF0700.4BXXA2	600	513	559	380	300	14	30	344	13	20	11	20	20	60	10	432	210	400	195	160	5	M5x20	-	-	-	422	5
SWF0800.4BXXA2	600	556	559	380	330	14	30	374	13	40	11	40	20	80	10	450	338	422	150	410	9	M8x20	29	20	6	464	6
SWF0900.4BXXA2	600	554	559	380	330	14	30	374	13	40	11	40	20	80	10	450	338	422	150	410	9	M8x20	29	20	6	535	6
SWF1000.4BXXA2	600	549	559	380	330	14	30	374	13	40	11	40	20	100	10	450	338	422	150	410	9	M8x20	29	20	6	576	6

CASE 3

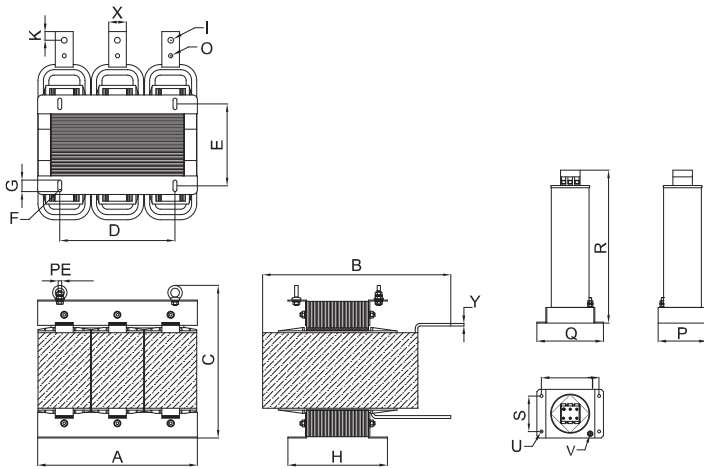

CASE 4

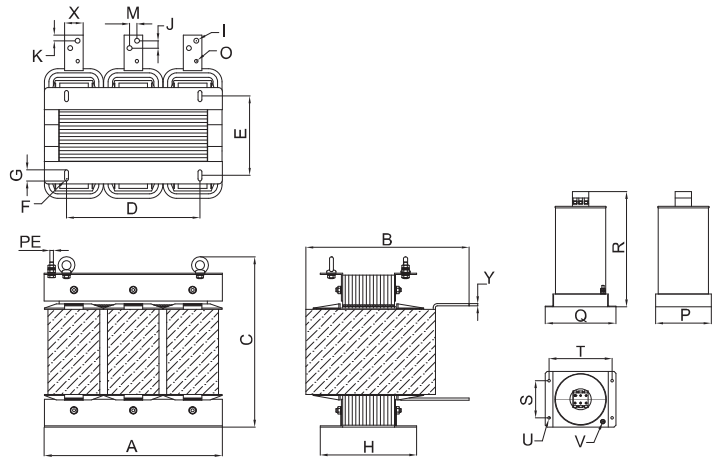

CASE 5

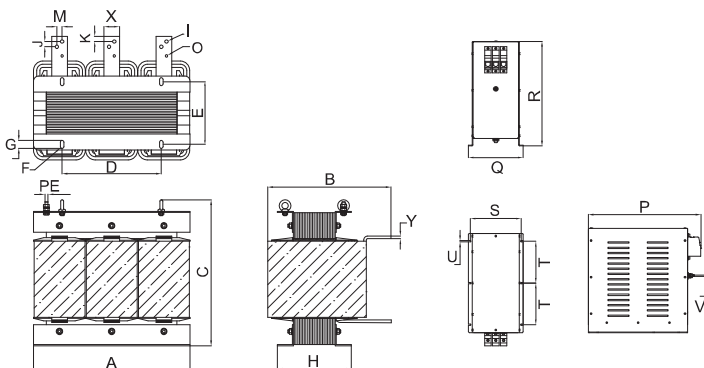

CASE 6

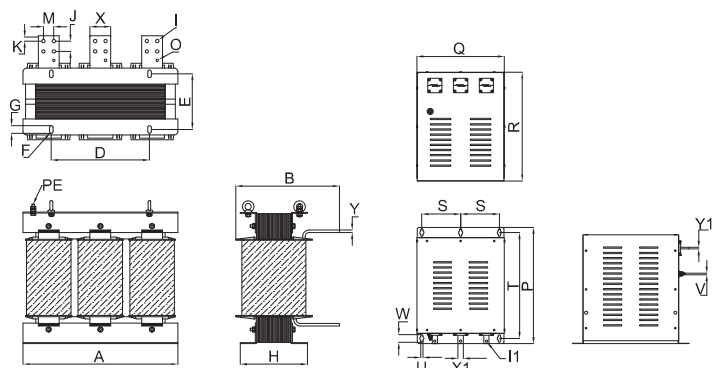



Datasheet 202405

High frequency sine wave filter with excellent attenuation for variable frequency drive applications

APPROVALS:

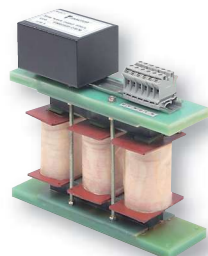

FIN915SFH.(005 - 048).M

FEATURES

- Rated current from 5 to 1100A
- High performance sine wave output
- Eliminates dV/dt and increases motor life
- Ideal for high speed motors

BENEFITS

- Terminal blocks up to 880A
- Very compact design
- Available in open frame or enclosure

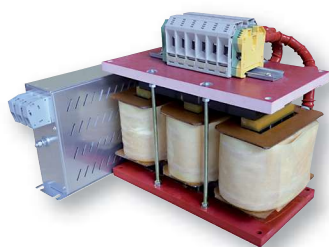

FIN915SFH.(060 - 360).M

MARKETS

- Long cable applications - 2,500m
- Frequency drives and servo drives >75 Hz
- Process plants
- Water treatment plants
- Agriculture

ORDERING CODE

FIN915SF	.100	.M	-N1
Model	Current (A)	Connection	Enclosure
		M = Terminal	N1 = Nema 1
		V = Screws	N3R = Nema 3R
		BC = Bus bar	

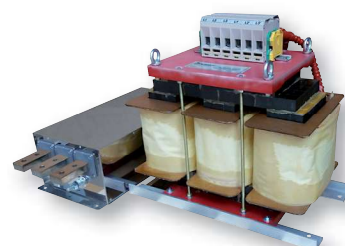

FIN915SFH.(480 - 1100).M

ATTENUATION INDICATOR

High	Very High	Excellent

ELECTRIC DIAGRAM

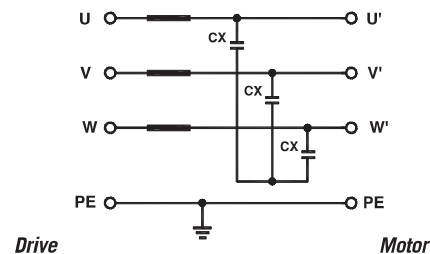

TECHNICAL SPECIFICATIONS

Nominal voltage	0 - 600 Vac
Output frequency	0 - 3 kHz
Rated current	5 - 1100 A
Carrier frequency (PWM)	>2 kHz, see table
Ambient temperature	70°C
Altitude	1000 m
Relative humidity	<95% no condensation
Saturation current	4 x Rated Current (Switch ON) 2 x In 10 seconds 1.5 x In 10 minutes 1.5 x Nominal current
IP Protection	IP20 up to 360A IP00 over 480A
Optional	Enclosure, fan, finger safe protection

MECHANICAL DIMENSIONS mm

FIN915SFH	A	B	C	D	E	F	G	Weight Kg.	Case
.005.M	260	170	252	240	110	8	138	5	1
.010.M	260	170	252	240	110	8	138	6.5	1
.016.M	260	170	252	240	110	8	138	8	1
.025.M	300	240	265	280	140	8	160	12	2
.036.M	300	240	265	280	140	8	160	14	2
.048.M	300	240	265	280	140	8	160	17	2

CASE 1, 2

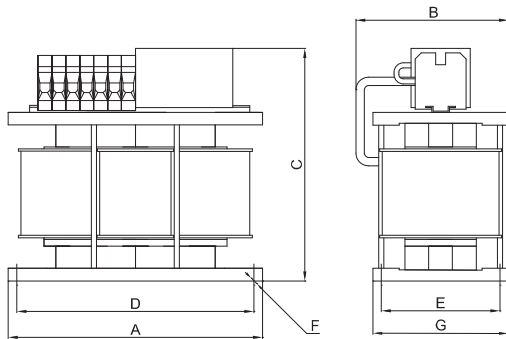

FIN915SFH	A	B	C	D	E	F	G	I	L	N	P	R	dØ	V	Weight Kg.	Case
.060.M	400	250	335	370	170	12	260	293	100	120	135	5	5	180	30	3
.075.M	540	360	460	500	200	12	260	293	100	120	135	5	5	180	38	3
.115.M	540	360	460	500	200	12	260	389	130	205	220	5	5	260	63	4
.140.M	540	360	460	500	200	12	260	389	130	205	220	5	5	260	80	4
.180.M	540	320	465	500	200	12	260	389	130	205	220	5	5	260	83	4
.210.M	540	320	465	500	200	12	260	450	150	280	295	5	5	260	88	5
.260.M	540	320	465	500	200	12	260	450	150	280	295	5	5	260	110	5
.360.M	540	320	465	500	200	12	260	450	150	280	295	5	5	260	150	5

CASE 3, 4, 5

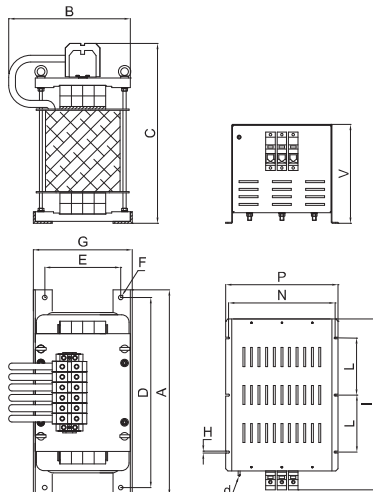

MECHANICAL DIMENSIONS mm

FIN915SFH	A	B	C	D	E	F	G	I	L	N	P	V	H	d	S	Weight Kg.	Case
.480.M	540	340	475	500	200	12	260	620	660	244	295	262	16	M5	25x10	115	6
.610.M	540	340	475	500	200	12	260	620	660	244	295	262	16	M5	25x10	120	6
.680.M	540	340	475	500	200	12	260	830	790	244	292	292	16	M5	25x10	126	7
.770.M	540	340	475	500	200	12	260	830	790	244	292	292	16	M5	25x10	130	7
.860.M	540	340	475	500	200	12	260	885	830	474	520	292	16	M5	40x20	135	8
.960.M	540	340	475	500	200	12	260	885	830	474	520	292	16	M5	40x20	150	8
.1100.M	540	340	475	500	200	12	260	885	830	474	520	292	16	M5	40x20	200	8

CASE 6, 7, 8

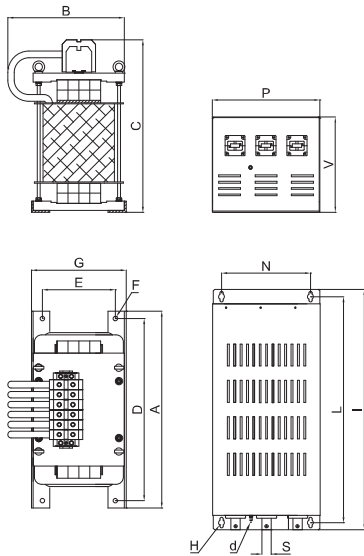



Datasheet 202405

Three-phase plus neutral star point snubber with excellent attenuation to reduce dV/dt

APPROVALS:



FIN47SNB.050.1M

FEATURES

- Reduces dV/dt
- Protects motor windings, insulation and bearings
- Remote contact indicator

BENEFITS

- Very low power loss
- Available with remote electronic control
- Easy installation
- Only one model for unlimited HP motors

MARKETS

- Large motors
- Spindle motors
- Long cable applications with variable frequency drives or servo drives

ORDERING CODE

FIN47SNB	.050	.1M	.A	MSD1	.F
Model	Impedance	Connection	Fan nominal voltage	Electronic control or HV version	Flange mounting
		1M = 1 motor	A = 24Vdc B = 24Vac	MSD1 at 24Vdc	
		2M = 2 motors	C = 110Vac D = 220Vac	MSD2 at 230Vac HV 690Vac	

TYPICAL MEASUREMENT

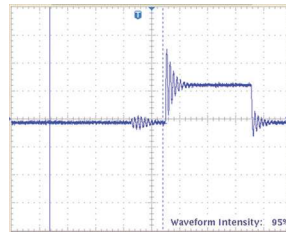

Typical measurement of dV/dt without snubber installed

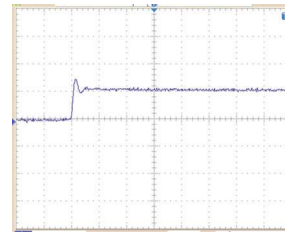

Typical measurement of dV/dt with snubber installed

ELECTRIC DIAGRAM

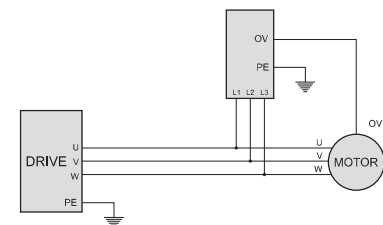

TECHNICAL SPECIFICATIONS

Nominal voltage	0 - 600 Vac
Frequency	50 - 1000 Hz
Rated current	Unlimited
Carrier frequency (PWM)	Not applicable
Max peak voltage phase to phase	3000V
Max peak voltage phase to ground	3500V
Max power dissipation	250W
Fan dissipation	20W
IP protection	IP20
Climatic class	-40 to 85°C
MTBF at 40°C	250,000 Hours

ELECTRICAL CHARACTERISTICS

FIN47SNB	Nominal Voltage AC (Vac)	Drive Carrier Frequency (kHz)	Power Loss at 100Hz (W)
.050.1M	600	<5	250

CONNECTIONS

LINE			PE	
Solid Cable (mm ²)	Stranded Cable (mm ²)	Terminal Torque (Nm)	d (mm)	Torque (Nm)
10 - 50	10 - 50	4.0	M10	6

MECHANICAL DIMENSIONS mm

FIN47SNB	A	B	C	D	E	F	G	H	I	J	M	L	d	Weight Kg.	Case
.050.1M.X.Y	235	224	252	125	110	83	125	8.5	4	13.5	10	15	M10	5	1
.050.2M.X.Y	235	368	376.5	125	110	83	105	5.4	4	8.5	-	15	M10	10	2
.050.1M.X.Y.F	235	224	252	155	145	150	-	6	-	-	10	15	M10	5	3
.050.2M.X.Y.F	235	368	376.5	155	145	140	-	6	-	-	-	15	M10	10	4

CASE 1

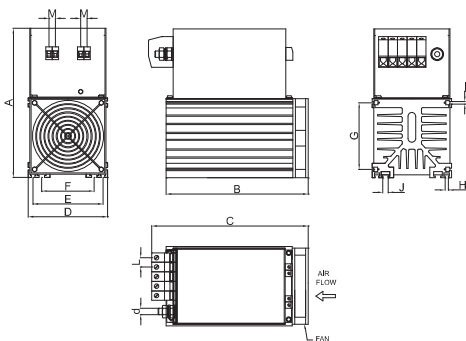

CASE 2

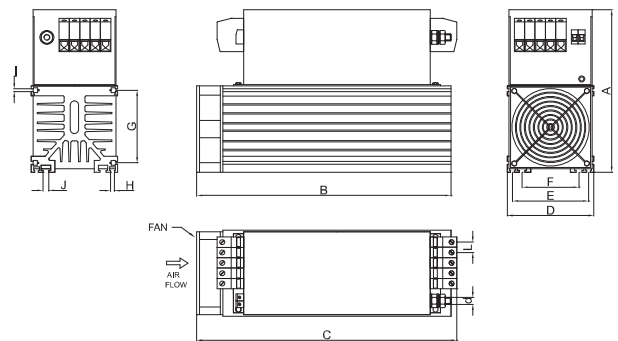

CASE 3

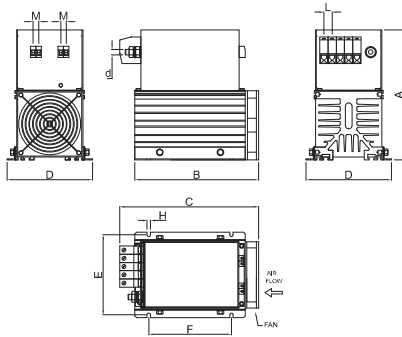

CASE 4

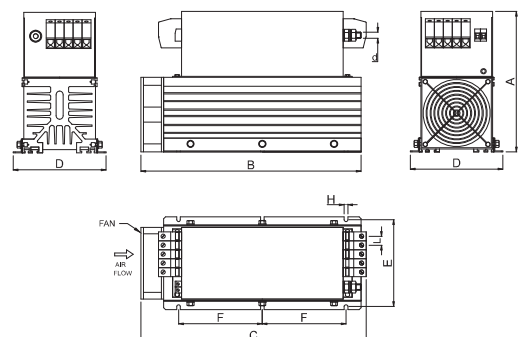

FIN47SNB	A	B	C	D	E	F	G	H	I	J	M	L	d	Weight Kg.	Case
.050.1M.X.Y.MDSX	235	368	368	155	145	140	-	6	-	-	-	15	M10	7	1
.050.1M.X.Y.HV	235	368	368	155	145	140	-	6	-	-	-	15	M10	7	1

CASE 1

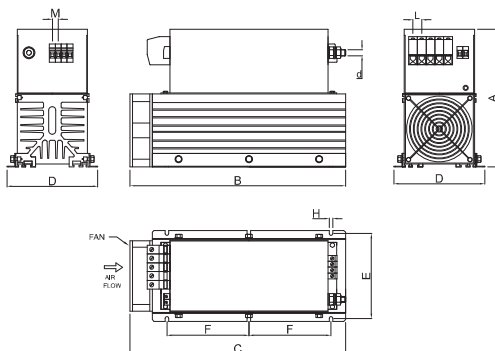



Star point snubber with excellent attenuation to reduce dV/dt

Datasheet 202405

APPROVALS:



FINSTP.(068 - 100).M100

FEATURES

- Reduces dV/dt star point -PE
- Protects motor windings, insulation and bearings
- Remote contact indicator
- Compact dimension due to the parallel installation

BENEFITS

- Very low power loss
- Over temperature protection
- Easy installation
- Only one model for unlimited HP motors

MARKETS

- Large motors
- Spindle motors
- Long cable applications with variable frequency drives or servo drives

ORDERING CODE

FINSTP	.068	.M100	.A	.F
Model	Impedance	-	Fan nominal voltage	Flange mounting
			A = 24Vdc	
			B = 24Vac	
			C = 110Vac	
			D = 220Vac	

ATTENUATION INDICATOR

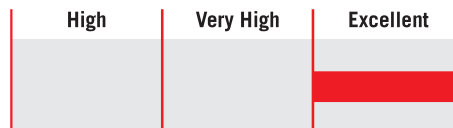

ELECTRIC DIAGRAM

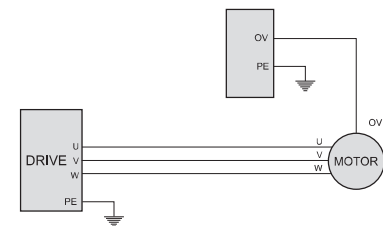

TECHNICAL SPECIFICATIONS

Nominal voltage	0 - 600 Vac
Frequency	50 - 1000 Hz
Rated current	Unlimited
Carrier frequency (PWM)	Not applicable
Max peak voltage phase to phase	3000V
Max peak voltage phase to ground	3500V
Max power dissipation	250W
Fan dissipation	20W
IP protection	IP20
Climatic class	-40 to 85°C
MTBF at 40°C	250,000 Hours.

ELECTRICAL CHARACTERISTICS

FINSTP	Nominal Voltage AC (Vac)	Drive Carrier Frequency (kHz)	Power Loss at 100Hz (W)
.068.M100.X	600	<5	200
.100.M100.X	600	<5	200
.068.M100.X.F	600	<5	200
.100.M100.X.F	600	<5	200

CONNECTIONS

Solid Cable (mm ²)	LINE		Terminal Block Torque (Nm)	PE Torque (Nm)
	Solid Cable (mm ²)	Stranded Cable (mm ²)		
10-50	10-50	10-50	4.0	6
10-50	10-50	10-50	4.0	6
10-50	10-50	10-50	4.0	6
10-50	10-50	10-50	4.0	6

TYPICAL MEASUREMENT

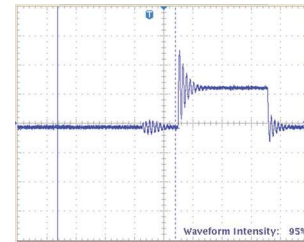

Typical measurement of dV/dt without snubber installed

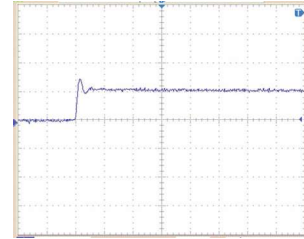

Typical measurement of dV/dt with snubber installed

MECHANICAL DIMENSIONS mm

FINSTP	A	B	C	D	E	F	G	H	I	J	M	L	Weight Kg.	Case
.068.M100.X	190	167	189.5	125	110	83	105	5.4	4	8.5	10	20	4	1
.100.M100.X	190	167	189.5	125	110	83	105	5.4	4	8.5	10	20	4	1
.068.M100.X.F	190	167	189.5	155	145	100	-	6	-	-	10	20	4	2
.100.M100.X.F	190	167	189.5	155	145	100	-	6	-	-	10	20	4	2

CASE 1

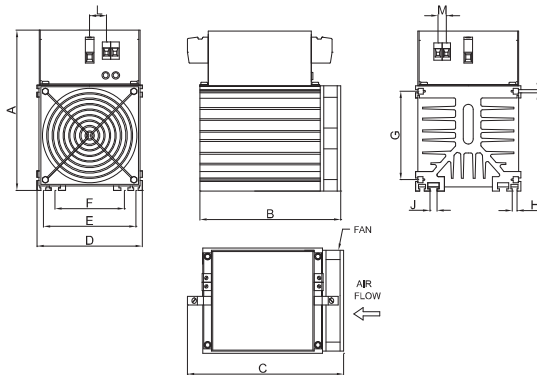

CASE 2

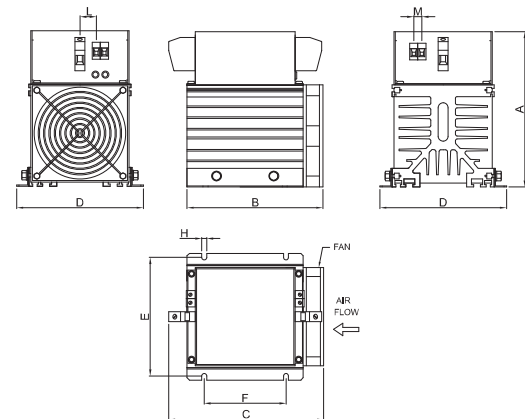



Datasheet 202405

High permeability toroid and ferrite core to reduce common mode noise

APPROVALS:



FINTR.(3600 - 14000)
FINFE.13

FEATURES

- Insulation housing included
- FINTR with high permeability
- Available in various sizes

BENEFITS

- Easy installation
- Ideal for radiated emission tests for the EN61000-6-4 Standard

MARKETS

- Indoor and outdoor applications

ORDERING CODE

FINTR .4900
Model
TR = Toroid Size
FE = Ferrite

FINTR	Permeability μ
.3600	5000
.4900	10000
.6300	10000
.10000	5500
.14000	5500

FINFE.13	
Frequency (MHz)	Impedance (Ohm)
25	150
100	250

MECHANICAL DIMENSIONS mm

FINTR	A	B	C	Weight Kg.	Case
.3600	37	22	16	0.04	1
.4900	49	34	16	0.08	1
.6300	63	38	25	0.25	1
.10000	102	66	15	0.36	1
.14000	140	106	25	0.80	1

FINFE	A	B	C	D	Weight Kg.	Case
.13	31	32	13	33	0.1	2

CASE 1

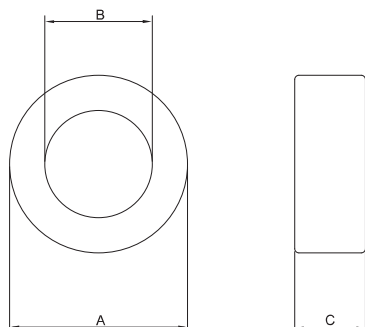

CASE 2

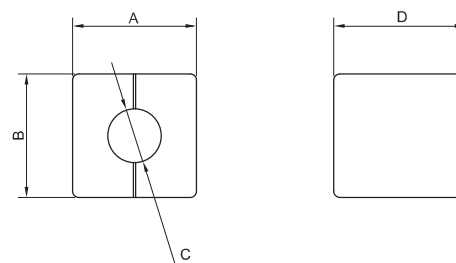

Enerdoor offers a range of accessories designed to elevate functionality and safeguarding measures.

The FINPRT series prioritizes safety with finger-safe protection, specifically engineered for EMI/RFI filters with bus bar connections. This ensures ease of installation while maintaining optimal safety standards.

The FINENCL series presents enclosures with IP21 (NEMA 1) and IP44 (NEMA 3R) ratings, catering to both indoor and outdoor installations. This versatility extends to various applications involving line reactors, output filters, and sine wave filters.

With user-friendly installation features and the option for an additional fan, these accessories are tailored to enhance adaptability and performance across diverse settings.





Datasheet 202405

Protection covers for filters with high currents and bus bar connections

APPROVALS:



FEATURES

- Rated current from 150 to 1750A

BENEFITS

- Easy installation
- Increases IP protection

MARKETS

- Enerdoor filter with bus bar connection

ORDERING CODE

FINPRT .250 .P
Model Size Connection
P = Protection

FINPRT.(250 - 1000).P

FINPRT	FIN1200 / FIN1200HV	FIN1500 / FIN1500HV	FIN538S1	FIN539S
.250.P	.150.V	.150.V	.150.V	-
	.200.V	.200.V	.200.V	.200.V
	.280.V	.280.V	.280.V	.280.V
	.280.BC	.280.BC	.280.BC	.280.BC
	.320.BC	.320.BC	.320.BC	.320.BC
.360.P	.360.BC	.360.BC	.360.BC	.400.B
	.400.BC	.400.BC	.400.BC	.500.B
	.500.BC	.500.BC	.500.BC	.600.B
	.600.BC	.600.BC	.600.BC	.750.B
	.750.BC	.750.BC	.750.BC	.900.B
.750.P	.900.BC	.900.BC	.900.BC	.1000.B
	.1000.BC	.1000.BC	.1000.BC	.1250.B
	.1250.BC	.1250.BC	.1250.BC	.1500.B
.1000.P	.1500.BC	.1500.BC	.1500.BC	.1750.B
	.1600.BC	.1600.BC	.1600.BC	.2000.B
	.1750.BC	.1750.BC	.1750.BC	.2250.B

MECHANICAL DIMENSIONS mm

FINPRT	A	B	C	D	E	Case
.250.P	135	115	250	270	110	1
.360.P	135	115	260	280	150	1
.750.P	165	145	280	300	180	1
.1000.P	165	145	380	400	200	1

CASE 1

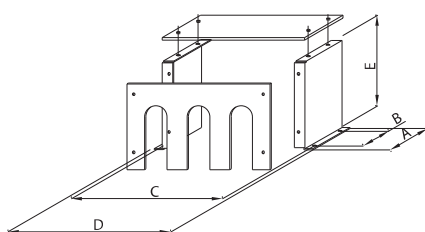

ASSEMBLY

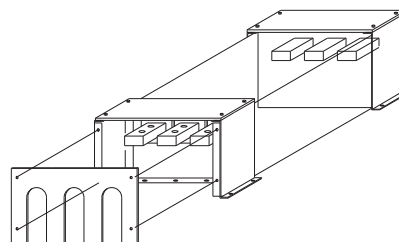



Enclosures for line reactors, high-frequency inductors, and sine wave filters

Datasheet 202405

APPROVALS:



FINENCL.(31 - 101)

FEATURES

- Different IP protections available
- Used for line reactors, output filters and sine wave filters

BENEFITS

- Easy installation
- Fan available upon request



FINECL.(A - D)

MARKETS

- Indoor and outdoor applications

ORDERING CODE

COF .31

Model Size

FINENCL	IP Protection (Nema)	W	D	H	Weight Kg.	Case
.31	IP21 (Nema 1)	340	340	330	7	1
.41	IP21 (Nema 1)	340	340	380	9	1
.51	IP21 (Nema 1)	390	390	430	12	1
.61	IP21 (Nema 1)	490	370	480	16	1
.71	IP21 (Nema 1)	540	440	590	22	1
.81	IP21 (Nema 1)	640	490	695	30	1
.101	IP21 (Nema 1)	800	800	800	43	1
.A	IP44 (Nema 3R)	450	360	620	23	2
.B	IP44 (Nema 3R)	610	460	720	35	2
.C	IP44 (Nema 3R)	810	560	920	56	2
.D	IP44 (Nema 3R)	1306	1000	1426	95	2

CASE 1

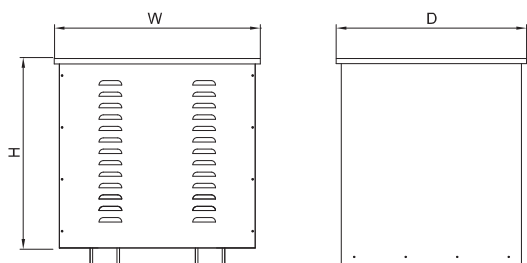

CASE 2

